

AVIM® FAMILY

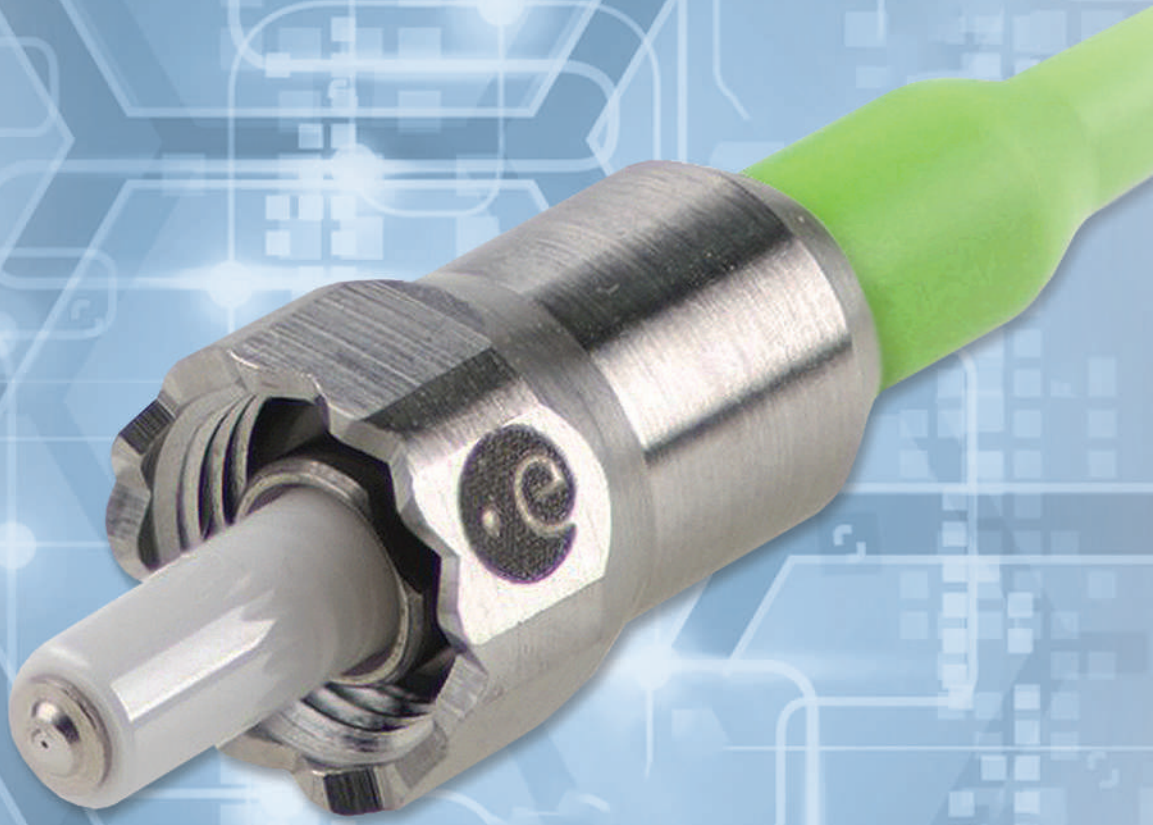

CONTENT

AVIM® Family	3
Space applications	4
<hr/>	
AVIM®	7
Specifications	8
Adapter and dimensions	9
Connector and dimensions	10
<hr/>	
Midi AVIM®	11
Specifications	12
Connector types and dimensions	13
<hr/>	
Mini AVIM®	14
Specifications	15
Adapter and dimensions	16
Connector dimensions	17
<hr/>	
Micro AVIM®	18
Specifications	19
Connector types and dimensions	20
<hr/>	
Facilities	21
<hr/>	
Part Number	22
<hr/>	

DIAMOND Fiber Optic Components

CABLE ASSEMBLIES, ADAPTERS, IMODs AND TOOLS

The AVIM® connector is born in mid 1990's as a vibration resistant connector for avionics and space application. Since then, the evolution of these connectors has been driven by harsh environment applications, especially for Aerospace and Naval applications.

In a first step, AVIM® has been adapted to Naval applications, then by 2009, a lighter and rugged version was commissioned for a Mars rover, the Mini AVIM®. This connector has been used in various application due to its exceptional environmental resistance characteristics, and to its high end optical performance benefitting from Diamond unique ferrule designs and technologies.

An intermediate version, the Midi AVIM® is coming to complete this family of shock and vibration resistant small single channel fiber optic connectors.

In the next pages, you will discover the different applications where these products are deployed, a description of Diamond's Space Grade process for Flight models that must follow the European Space Agency standards and the various products themselves, as well as tools and services provided by Diamond.

APPLICATIONS

SPACE

Active since mid-1990's in the space market, Diamond products have a long heritage in space, mainly used by NASA GSFC and more recently standardized by the ESCC, the European Space Components Coordination. The Mini AVIM® is Diamond's only ESCC standardized component, but Diamond produce other flight models for custom configurations. The historically mostly used space connector, the AVIM®, due to commercial reasons, has not been standardized under ESCC but is still available, using the same Space Grade or Commercial Grade process as the Mini AVIM®.

You can find connectors from Diamond from Mercury, on Mars, around the moon, mostly around the earth and soon toward Jupiter.

The Space applications have been divided in three groups:

1. Sensing
2. Inter-satellite communication
3. Intra-satellite communication

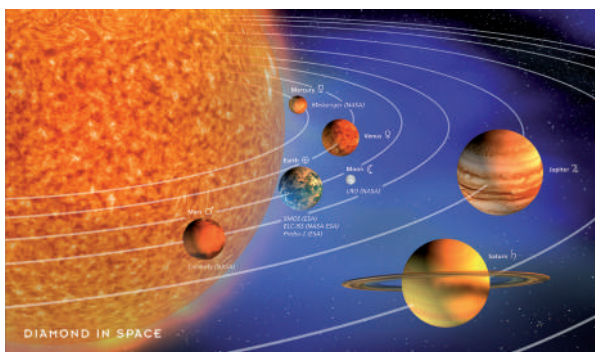

DIAMOND SA | Via dei Patrizi 5 | CH-6616 Losone - Switzerland
Tel. +41 58 307 45 45 | e-mail info@diamond-fo.com

www.diamond-fo.com

AVIM® Family

AVIM®
Midi AVIM®
Mini AVIM® (ESCC 3420/001)
Micro AVIM®
CLEANING KIT



AVIM®



Midi AVIM®



Mini AVIM®



Micro AVIM®



Cleaning Kit

*Specifications subject to change
without notice*

BDD 1951881 03_24

Sensing

The sensing applications are numerous, probably driven by Lidar or Laser Altimeter, but numerous other applications have been seen, using optical fiber from low wavelength, small core single mode polarization maintaining to large core multimode.

It is almost impossible to standardize those applications and these are the most demanding, as the pass/fail criteria can be quite different than the standard digital communication application because other properties from the light are used, such as wavelength, intensity, phase, polarization,...

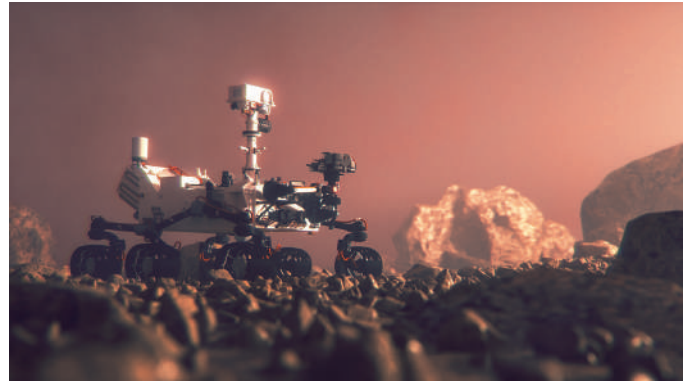
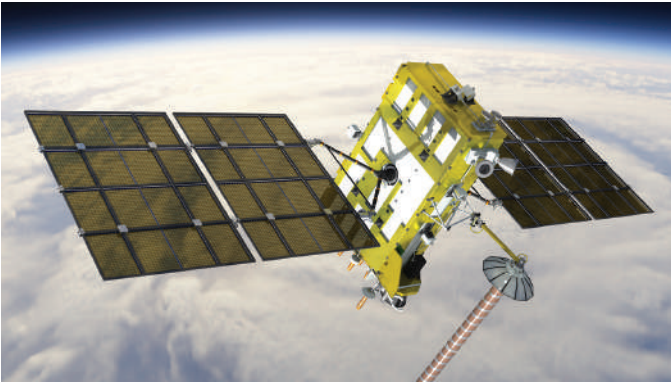

Inter-satellite Communication

With optical signal, a line of sight is necessary to bring the data on the ground and it is not always possible from any satellite position. For this reason, communication between satellite, even planes, unmanned vehicle or balloons is required. Constellation of hundreds of satellites are discussed, each would require a communication terminals, which are already commercially available or in development.



Intra-Satellite communication

Telecom satellites are using up and down-link using radio waves and use electric cable internally (several tons). The challenge to change these payloads in fiber optic, improving dramatically weight, power dissipation and power consumption can change dramatically the face of communication via satellite. A typical telecom satellite would have a thousand connections to be replaced by optical fibers.

PRODUCT GRADES

The AVIM® family products comes in four quality grades varying in the procurement and production process, but sharing the same components.

- ▶ Commercial Grade CG
- ▶ Space Grade SG
- ▶ Enhanced Grade EG
- ▶ Customized Grade CUST

Commercial Grade, CG

- ▶ Standard procurement process
- ▶ Performance according to datasheet
- ▶ Qualification Test Report according to IEC standards mostly
- ▶ Standard Packaging
- ▶ 3-4 weeks typical lead time

Space Grade, SG

- ▶ Space procurement process
 - Customer specification acceptable, fee based Compliance Matrix
 - Traceability according to prescription from RFQ, standard traceability covered by ESCC certificate 355
 - All travel cards archived 10 years
 - Specific Quality management process, inspired by ESCC
 - Offer containing Diamond performance specification document, PSD
 - 100% Screening
 - Clean room packaging included
- ▶ Production according to confidential, ESA deposited, Product Identification Document (PID)
 - Material Deviation list (MDL) declared in PSD
 - Process Deviation List (PDL) declared in PSD
- ▶ Performance according to ESCC standards certified by ESCC certificate 355 or according to PSD/Compliance Matrix.
- ▶ Qualification Test Report according to ESCC 3420 available
- ▶ Superior reliability due to 100% screening
- ▶ Lot Verification Test, LVT, also called Lot Acceptance Test, based on a full or partial Chart F4 of ESCC 3420, available on demand and described in a Product Test Sequence (PTS).
- ▶ 9-10 weeks typical lead time

Enhanced Grade, EG

- ▶ Space procurement process with restriction
 - Traceability and Quality management according to Diamond SG standards
 - All travel cards archived 10 years
 - Offer containing Diamond performance specification document, PSD
 - No Screening
 - Clean room packaging included
- ▶ Not applicable to Mating adapter or IMOD (SG or CG)
- ▶ Production according to Diamond assembly process identical to SG
- ▶ Performance according to PSD documents
- ▶ Not recommended for flight model, use SG for better reliability
- ▶ Qualification Test Report available
- ▶ 6 weeks typical lead time

Customized, CUST

- ▶ Product, assembly process, procurement process customized
- ▶ Will follow either standard or space procurement process
- ▶ No systematic process qualification by similarity
- ▶ Require a Setup Fee for each case

PRODUCT OVERVIEW

	AVIM®	Midi AVIM®	Mini AVIM®	Micro AVIM®
Connector interface standards (compatible and exceeding)	IEC 61754-3 100% compatible DIN LSA	Diamond Midi AVIM® Mini AVIM™ mating adapter Partial ESCC 3420/001	Diamond Mini AVIM® ESCC 3420/001	Diamond Micro AVIM® Partial ESCC 3420/001
Materials (see datasheet for details)	Nickel-Silver, Stainless steel for springs and keyed nose, Hytrel® 8068 vacuum baked for boot	Titanium, Stainless steel for springs, Hytrel® 8068 vacuum baked for boot	Titanium, Stainless steel for springs, Hytrel® 8068 vacuum baked for boot	Titanium, CuBe clip
Optical interface standards	IEC 61755-3-7 (PC) IEC 61755-3-8 (APC) Diamond PM Diamond MM	IEC 61755-3-7 (PC) IEC 61755-3-8 (APC) Diamond PM Diamond MM	IEC 61755-3-7 (PC) IEC 61755-3-8 (APC) Diamond PM Diamond PS, PM-PS Diamond PSf, PM-PSf	IEC 61755-3-7 (PC) IEC 61755-3-8 (APC) Diamond PM Diamond PS, PM-PS Diamond PSf, PM-PSf
Active Core Alignment (ACA)	✓	✓	✓	✓
Active Polarization Orientation (APO)	✓ limited	✓	✓	✓
Power Solution collimation (PS)	✓	✓	✓	✓
High Temperature (HAT)	CG, SG, EG, CUST	CG, SG, CUST	CG, SG, EG, CUST	CG, SG, EG, CUST
Product Quality Grades				
Cable compatibility	Fiber and loose tube or TB Cable up to 3.5mm Stainless steel reinforced cable	Fiber and loose tube or TB Cable up to 2.1mm Stainless steel reinforced cable	Fiber and loose tube or TB Max 1.2mm	Fiber and loose tube or TB Max 1.2mm
Target Application	Avionics	Avionics / Space Vibration environment	Space rover Small ultra compact instrument	Space rover Small ultracompact instrument
Performance Qualification IEC 61753-2-1 cat. U uncontrolled	✓ TR-005 (SM)	✓ QTR-114	✓ QTR-040 (SM) ✓ QTR-111 (PM) ✓ QTR-117 (PSm)	✓ QTR-091 (SM) ✓ QTR-099 (PM) ✓ QTR-069 (PS)
Reliability Qualification IEC 62005-9-1 an additional Telcordia GR-326 extended humidity test				✓ TR-037 (DMI PM) ✓ TR-034 (DMI PS)
Harsh Environment qualification	✓ QTR-064 (AVIM ESCC)	✓ QTR-114	✓ QTR-065	
ESA ESCC 3420 Qualification		Compatibility with mating adapter	✓ ESCC certificate 355	
IL, Insertion Loss	++	+++	+++	+++
RL, Return loss	++	+++	+++	+++
ER, Extinction Ratio	++	+++	+++	+++
Handling	Tools required	Easy, no tools required	Delicate, require tools	Delicate, require tools
Connector mass	7	2.8	1.2	0.4
Mating adapter mass Square(hexagonal)	9.7 (7.5)	2.7	2.7	0.6g (TBC)
Connector parts	13	11	6	2

DIAMOND

Fiber Optic Components

AVIM®

SINGLE MODE	PC/APC
MULTIMODE	PC
PM	PC/APC
HIGH TEMP, HT	PC/APC

CABLE ASSEMBLIES AND ADAPTERS

Developed in the 1990's for aerospace application and compatible with the DIN LSA connector, the AVIM® is a multipurpose Commercial-Off-The-Shelf, COTS, fiber optic connector offering high optical performance and capable in dynamic environments of mobile platforms, including avionics and especially space flight.

These connectors are compatible with the widest range of optical fibers, including single mode (SM), multimode (MM), polarization maintaining (PM) and other fibers of different core/cladding sizes, multi-fiber ferrule and multi-core fibers.

High performance in the form of lowest insertion loss provided by Diamond's unique Active Core Alignment termination process as well as high return loss for the most demanding, high bandwidth transmission systems.

FEATURES

- ▶ Low IL due to Active Core Alignment (A.C.A.)
- ▶ High return loss due to Diamond ultra-polishing process and A.C.A
- ▶ High vibration/shock resistance due to Miniaturized MIL-style ratchet system
- ▶ AVIM® 2-piece cleanable adapter for front panel easy cleaning and maintenance access.
- ▶ IEC 61754-3 100% compatible with LSA (DIN) standard
- ▶ Tooling for installation mandatory

AVAILABLE AS

- ▶ Terminated connectors and assemblies with following optical interface
 - SM, MM, MM large core
 - PM or PZ
 - Multi-fiber Ferrule
- ▶ Components:
 - Connector Set (require Diamond production line)
 - Mating adapters
 - Interface Module IMOD
- ▶ Product grades:
 - Commercial Grade, CG
 - Enhanced Grade, EG
 - Space Grade, SG
 - Customized CUST

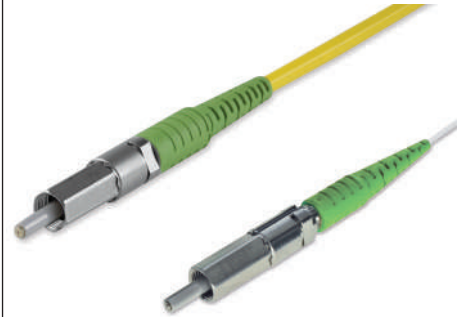

SPECIFICATIONS

The products are available in different grade, changing the operating range and performance. Two tables are provided: Optical performance at room temperature and list of test performed on each product grade.

COMMERCIAL GRADE, CG	SINGLE MODE	MULTIMODE	PM APC 8°	UNITS	TEST CONDITIONS
Insertion loss, IL max	typ. 0.2, max 0.4	typ. 0.2, max 0.4	typ. 0.2, max 0.4	dB	IEC 61300-3-4 method B, λ=1550nm
Return loss, RL min	50 (PC), 75 (APC)	40 (PC)	50 (PC), 75 (APC)	dB	IEC 61300-3-6, λ=1550nm
Polarization extinction ratio, ER min	-	-	typ 27, min 23	dB	Diamond validated cross polarizers, low coherence method, λ=1550nm
Polarization angular error, α	-	-	± 2	°	
Repeatability of IL	<= 0.2			dB	IEC 61300-2-2 method B, λ=1550nm
Service life	500 mate/demate cycles			dB	
Operating temperature	-40 to +85			C°	

ENHANCED AND SPACE GRADE, EG AND SG	SINGLE MODE	MULTIMODE	PM APC 8°	UNITS	TEST CONDITIONS
Insertion loss, IL	typ. 0.25, max 0.5	typ. 0.2, max 0.4	typ. 0.2, max 0.5	dB	IEC 61300-3-4 method B, λ=1550nm
Return loss, RL	50 (PC), 75 (APC)	40 (PC)	50 (PC), 75 (APC)	dB	IEC 61300-3-4 method B, λ=1550nm
Polarization extinction ratio, ER	-	-	typ 25, min 21	dB	Similar to IEC 61300-3-40, low coherence, λ=1550nm
Polarization angular error, α	-	-	± 2	°	
Repeatability of IL	<= 0.4			dB	IEC 61300-2-2 method B, λ=1550nm
Service life	100 mate/demate cycles			dB	
Operating temperature	-55 to +85			C°	

- NOTES**
- Those values are at BOL, room temperature.
 - For specific fibers and wavelength, please inquire on the optical specification
 - Cable can further limit those values

ENVIRONMENTAL TESTS

	CG			SG and EG	
	LEVEL	METHOD		LEVEL	METHOD
Thermal cycles	-40°C to +85°C, 20 cycles	IEC 61300-2-22	Thermal cycles	-55°C to +85°C, 100 cycles	IEC 61300-2-22
Humidity	+40°C, 168h	IEC 61300-2-19	Humidity	+25°C to +55°C, 6 cycles, 144h	IEC 61300-2-46
Vibration	Sinus, 20g, 15cycles	IEC 61300-2-19	Vibration	Random, 35gRMS	IEC 60068-2-64
Shock	5 drops, 1.5m	IEC 61300-2-12	Shock	500g, 2ms	IEC 60068-2-27
Torsion	2N, 25 cycles 180°	IEC 61300-2-5	Torsion	2N, 25 cycles 180°	IEC 61300-2-5
Static side load	0.2N, 90°, 5min	IEC 61300-2-42	Static side load	0.2N, 90°, 60min	IEC 61300-2-42
Fiber/cable retention	5N, 1min	IEC 61300-2-4	Fiber/cable retention	5N, 2min	IEC 61300-2-4
High temperature storage	+85°C, 168h	IEC 61300-2-18	High temperature storage	+85°C, 1000h	IEC 61300-2-18
Mating durability	500	IEC 61300-2-22	Mating durability	100	IEC 61300-2-2
			Low pressure	4*10-8 Torr, 8h	IEC 60068-2-13
			Dust	30°C to 60°C, 2h	IEC 61300-2-27
			Salt mist	+35°C, 85% r.h, 5% salt, 96h	IEC 60068-2-11
			Rapid depressurisation	atm to 50mbar in 5s, 5 cycles	MIL-STD.810G

Qualification test reports describe in details tests and results.

TOOLING FOR ASSEMBLING

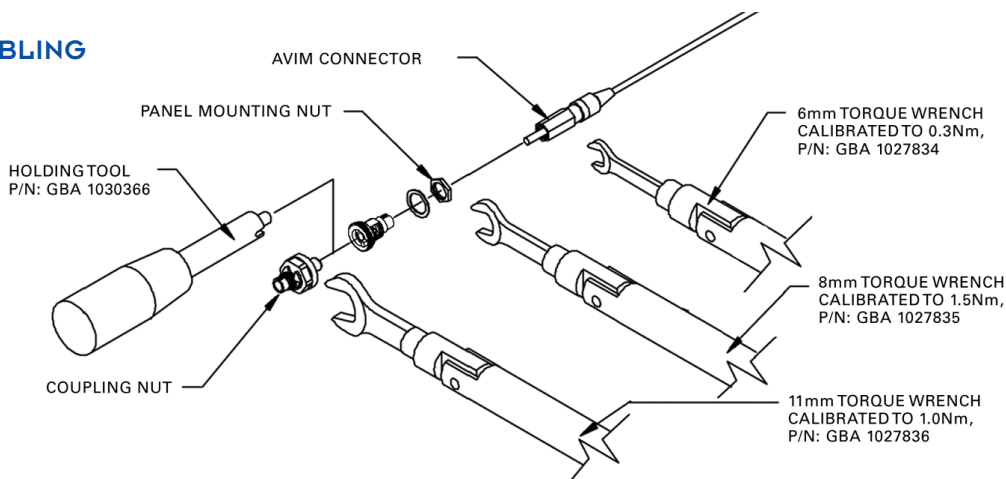

AVIM® ADAPTER AND DIMENSIONS

Available types: Hexagonal and square flange adapter for wall mount
 Material: According to part list

BILL OF MATERIAL - AVIM® MATING ADAPTER - SQUARE FLANGE

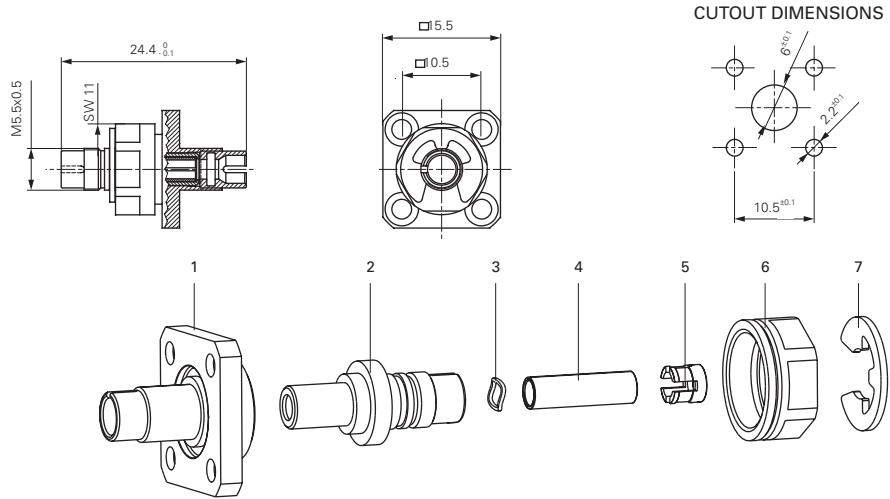

POS.	DESCRIPTION	MATERIAL	UNIT MASS (g)
1	Square flange	X10 Cr Ni S 18 9 (Inox)	4.93
2	Body	X10 Cr Ni S 18 9 (Inox)	1.77
3	Elastic washer	X12CrNi177	0.01
4	Elastic sleeve	ZrO2	0.20
5	Elastic ring	X10 Cr Ni S 18 9 (Inox)	0.08
6	Nut	X10 Cr Ni S 18 9 (Inox)	1.86
7	Serclip	X35CrMo17	0.24
Total			9.09

BILL OF MATERIAL - AVIM® MATING ADAPTER - HEXAGONAL FLANGE

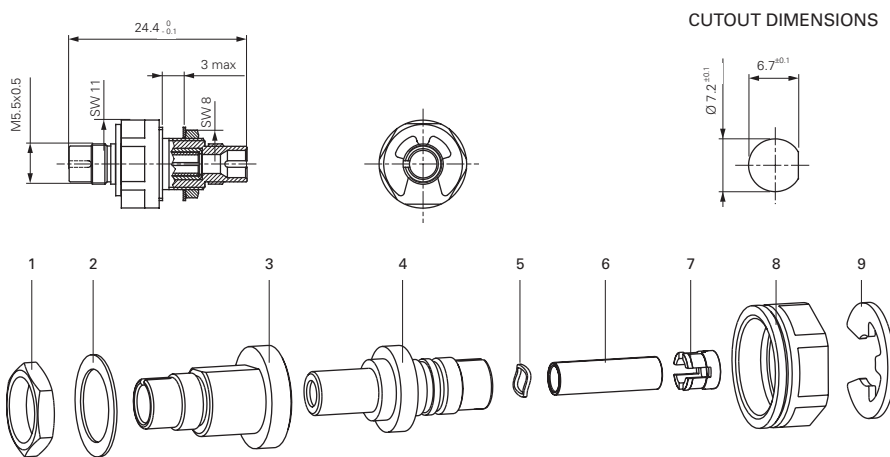

POS.	DESCRIPTION	MATERIAL	UNIT MASS (g)
1	Nut	X5 Cr Ni 18 10 (Inox)	0.31
2	Washer	CuSn6	0.09
3	D-shape body	X5 Cr Ni 18 10 (Inox)	2.60
4	Body	X10 Cr Ni S 18 9 (Inox)	1.77
5	Elastic washer	X12CrNi177	0.01
6	Elastic sleeve	ZrO2	0.20
7	Elastic ring	X10 Cr Ni S 18 9 (Inox)	0.08
8	Nut	X10 Cr Ni S 18 9 (Inox)	1.86
9	Serclip	X35CrMo17	0.24
Total			7.16

NOTE Other adapters are available, with square flange or not un-mountable. Please inquire for more information.

AVIM® CONNECTOR AND DIMENSIONS

Connectors for 900µm - 3mm, straight boot style

Available types: **AVIM® (PC, APC, PM, PS)**

Ferrule material: Zirconia/metal insert, custom upon request

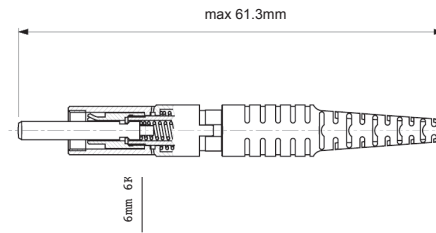

BILL OF MATERIAL - BOM

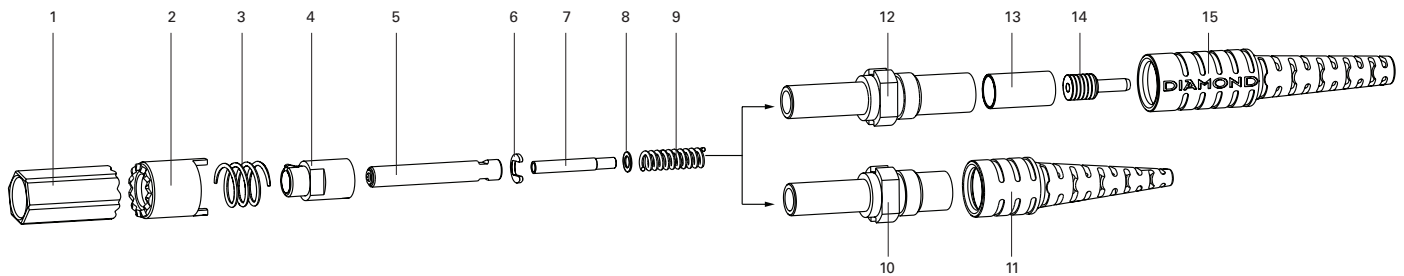

POS.	DESCRIPTION	MATERIAL	UNIT MASS (g)
1	Hexagonal ring	X5 Cr Ni 18 10 (Inox)	1.08
2	Antirotation ring	X5 Cr Ni 18 10 (Inox)	0.78
3	Anti-rotation spring	1.4310	0.13
4	Body Keyed nose	X10CrNiS189	0.48
5	Ferrule	ZrO2, titanium	0.27
6	Ferrule anti-rotation std	1.4301	0.01
7	Ferrule back tube	CuZn37	0.06
8	Ferrule ring for PM	CuZn37	0.01
9	Ferrule spring	X12CrNi177	0.10
10	Short Main body	X5 Cr Ni 18 10 (Inox)	2.02
11	Boot	Hytrel 8068 ¹	0.34
12	Long main body	X5 Cr Ni 18 10 (Inox)	1.40
13	Crimp ring (only with long main body)	Cu-5um Ni	0.77
14	Reductiononly (with long main body)	CuZn39Pb3	0.16
15	Long boot	Hytrel 8068 ¹	0.55
16	Protection cap (not displayed)	DIN 1.4310 or PPO Noryl V150	
Total			8.25

¹ Vacuum bake is 24h at 10-2 Torr and between 110°C to 125°C.

ORDER INFORMATION

Please refer to the part numbers provided in the separate P/N list.

For assemblies or other configurations, please contact your nearest local Diamond representative or fill in the contact form available on the www.diamond-fo.com website.

DIAMOND

Fiber Optic Components

CABLE ASSEMBLIES AND ADAPTERS

Following market feedback for a lighter version of the AVIM® connectors and the performance of the mini AVIM® connector, but with improved ease of use than the latter, the Midi AVIM® connector has been developed with the same optical high performance. In addition, the midi AVIM® has been made compatible with chosen aramid reinforced cables.

This connector performance is shared with the family, using identical ferrule technologies and has been made compatible with a large choice of fiber types.

FEATURES

The optical interface follows the standards as well as most of the connector types.

- ▶ Low IL due to Active Core Alignment (A.C.A.)
- ▶ High return loss due to Diamond ultra-polishing process and A.C.A
- ▶ High vibration/shock resistance due to Miniaturized MIL-style ratchet system
- ▶ Lightweight due to the use of titanium
- ▶ Compatible with Mini AVIM® mating adapters and IMOD
- ▶ ESCC 3420/001 configurable
- ▶ Tooling for installation mandatory

AVAILABLE AS

- ▶ Terminated connectors and assemblies with following optical interface
 - SM, MM, MM large core
 - PM or PZ
 - Multi-fiber Ferrule
- ▶ Components:
 - Connector Set (require Diamond production line)
 - Mating adapters (Mini AVIM®)
 - Interface Module IMOD (Mini AVIM®)
 - Custom assemblies
- ▶ Product grades:
 - Commercial Grade, CG
 - Customized CUST

Midi AVIM®

SINGLE MODE	PC/APC
MULTIMODE	PC
PM	PC/APC
HIGH TEMP, HT	PC/APC



SPECIFICATIONS

The products are available in commercial grade. Two tables are provided: Optical performance at room temperature and list of test performed.

COMMERCIAL GRADE, CG	SINGLE MODE	MULTIMODE	PM APC 8°	UNITS	TEST CONDITIONS
Insertion loss, IL max	typ. 0.2, max 0.4	typ. 0.2, max 0.4	typ. 0.2, max 0.4	dB	IEC 61300-3-4 method B, $\lambda=1550\text{nm}$
Return loss, RL min	50 (PC), 75 (APC)	40 (PC)	50 (PC), 75 (APC)	dB	IEC 61300-3-6, $\lambda=1550\text{nm}$
Polarization extinction ratio, ER min	-	-	typ 27, min 23	dB	Diamond validated cross polarizers, low coherence method, $\lambda=1550\text{nm}$
Polarization angular error, α	-	-	± 2	°	
Repeatability of IL	<= 0.2			dB	IEC 61300-2-2 method B, $\lambda=1550\text{nm}$
Service life	500 mate/demate cycles			dB	
Operating temperature	-40 to +85			C°	

- NOTES**
- Those values are at BOL, room temperature.
 - For specific fibers and wavelength, please inquire on the optical specification
 - Cable can further limit those values

ENVIRONMENTAL TESTS

	CG	
	LEVEL	METHOD
Thermal cycles	-40°C to +85°C, 12 cycles	IEC 61300-2-22
Humidity	+25°C to +55°C, 6 cycles, 144h	IEC 61300-2-46
Vibration	Random, 35gRMS	IEC 60068-2-64
Shock	100g, 2ms	IEC 60068-2-27
Torsion	15N, 25 cycles 180°	IEC 61300-2-5
Static side load	1N, 90°, 60min	IEC 61300-2-42
Fiber/cable retention	70N, 2min	IEC 61300-2-4
High temperature storage	+85°C, 96h	IEC 61300-2-18
Mating durability	500	IEC 61300-2-22

Qualification test reports describe in detail test and results.

TOOLING FOR ASSEMBLING

The same tool as for the mini AVIM® is to be used.

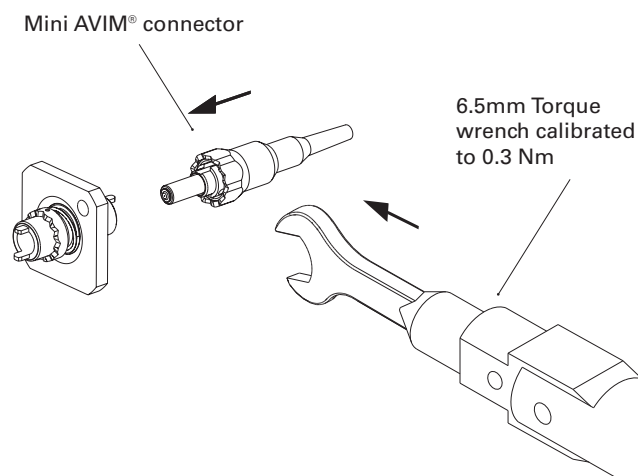

Midi AVIM® CONNECTOR TYPES AND DIMENSIONS

Connectors for 900um buffer coatings (or loose tube) with vacuum baked anti-flexion

Available types: **Midi AVIM® (PC, APC, PM)**

Material: According to part list

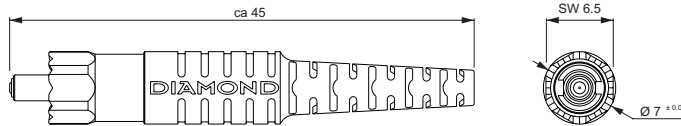

BILL OF MATERIAL - BOM

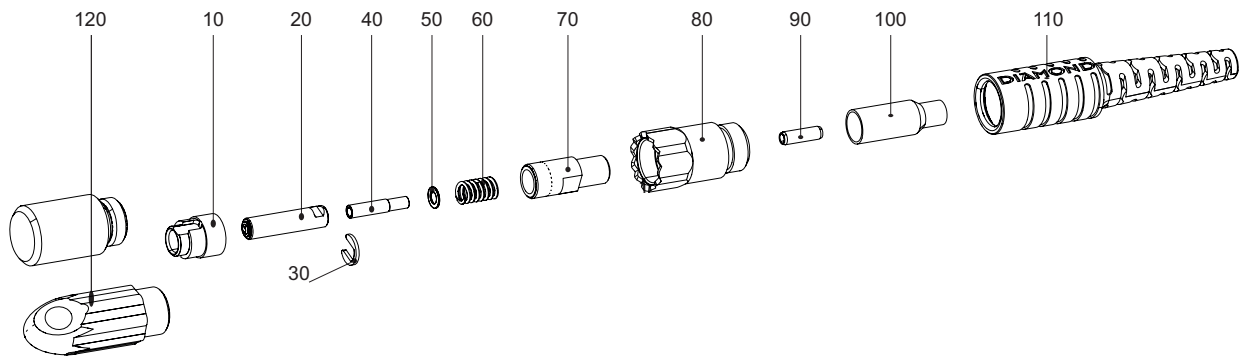

POS.	DESCRIPTION	MATERIAL	UNIT MASS (g)
10	Orientation ring	Ti6Al4V or DIN 3.7165	0.17
20	Ferrule	ZrO2 . -Ti gr 1	0.23
30	Orientation washer	AISI304 - DIN 1.4301	0.02
40	Ferrule tube	CuZn37	0.09
50	Washer	CuZn37	0.01
60	Ferrule spring	AISI301 - DIN 1.4310	0.05
70	Body	Ti6Al4V or DIN 3.7165	0.25
80	Locking nut	Ti6Al4V or DIN 3.7165	0.70
90	Crimping tube	CuZn213138	0.02
100	Crimp ring	Cu-5um Ni	0.28
110	Antiflexion boot	Hytrel® 8068 vacuum baked	0.83
120	Protection cap	PPO black Noryl V0150B	n.a.
	Protection cap metal	X10CrNiS189	n.a.
	Total		2.65

¹ Vacuum baked is 24h at 110°C to 125°C to 125°C and 10⁻³ Torr

NOTE Diamond's standard boot colors are as follows: Black for MM and SM PC, and green for SM APC.

ORDER INFORMATION

When ordering pigtails or cable assemblies, please refer to the **connector type description** in the Available types section.

DIAMOND

Fiber Optic Components

CABLE ASSEMBLIES AND ADAPTERS

The Mini AVIM® is originally a Diamond development for Exomars rover and has been standardized under ESCC 3420/001 Detail specification.

Born for space application with variants qualified for ESA and covered by ESCC certificate 355, the Mini AVIM® is born as a small connector for very harsh environment.

The Mini AVIM® combines two leading edge technologies: the AVIM® MIL-style ratchet system and the base construction of Diamond Micro Interface (DMI) connector.

The Mini AVIM® is a Commercial-Off-The-Shelf (COTS) connector that can be precisely aligned in rotation and therefore can be used for both standard SM and MM fibers, as well as for PM technologies and multi-fiber ferrules or multi-core fibers.

Our Power Solution (PS) technology can also be applied to this connector. The use of a 100% aligned GRIN lens spliced to the SM fiber allows to lower the power density at the output interface, and improve resistance to power failure due to particles.

Harsh environment applications will range from Space to underwater, applying to mobile, avionics, shipboard, oil downhole, etc.

FEATURES

- ▶ Low IL due to Active Core Alignment (A.C.A.)
- ▶ High return loss due to Diamond ultra-polishing process and A.C.A
- ▶ High vibration/shock resistance due to Miniaturized MIL-style ratche system
- ▶ Lightweight due to the use of titanium and simple design
- ▶ ESCC 3420/001 configurable
- ▶ ESA qualification certificate 355 for defined variants
- ▶ Tooling for installation mandatory

AVAILABLE AS

- ▶ Terminated connectors and assemblies with following optical interface
 - SM, MM, MM large core
 - PM or PZ
 - PS, PM-PS, PSf, PSm
 - Multi-fiber Ferrule
- ▶ Components:
 - Connector Set (require Diamond production line)
 - Mating adapters
 - Interface Module IMOD
- ▶ Product grades:
 - Commercial Grade, CG
 - Enhanced Grade, EG
 - Space Grade, SG
 - Customized CUST

Mini AVIM®

SINGLE MODE	PC/APC
MULTIMODE	PC
PM	PC/APC
PS, PM-PS, PSF	PC/APC 4°
PSM	PC
HIGH TEMP, HT	PC/APC

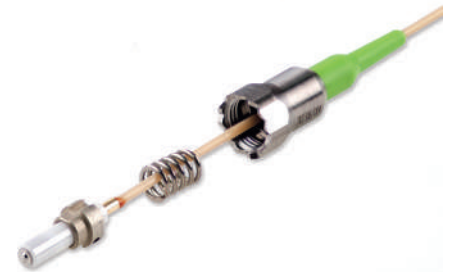

SPECIFICATIONS

The products are available in different grade, changing the operating range and performance. Two tables are provided: Optical performance at room temperature and list of test performed on each product grade. Some Space Grade variants are covered by ESCC qualification certificate 355 for space application.

COMMERCIAL GRADE, CG	SINGLE MODE	MULTIMODE	PM APC 8°	PS APC 4°	UNITS	TEST CONDITIONS
Insertion loss, IL max	typ. 0.2, max 0.4	typ. 0.2, max 0.4	typ. 0.2, max 0.4	typ. 0.2, max 0.4	dB	IEC 61300-3-4 method B, λ=1550nm
Return loss, RL min	50 (PC), 75 (APC)	40 (PC)	50 (PC), 75 (APC)	50 (PC), 75 (APC)	dB	IEC 61300-3-6, λ=1550nm
Polarization extinction ratio, ER min	-	-	typ 27, min 23	-	dB	Diamond validated cross polarizers, low coherence method, λ=1550nm
Polarization angular error, α	-	-	± 2	-	°	
Repeatability of IL	≤ 0.4				dB	IEC 61300-2-2 method B, λ=1550nm
Service life	500 mate/demate cycles				dB	
Operating temperature	-40 to +85				°C	

ENHANCED AND SPACE GRADE, EG AND SG	SINGLE MODE	MULTIMODE	PM APC 8°	PS APC 4°	UNITS	TEST CONDITIONS
Insertion loss, IL	typ. 0.25, max 0.5	typ. 0.2, max 0.4	typ. 0.25, max 0.5	TBD	dB	IEC 61300-3-4 method B, λ=1550nm
Return loss, RL	50 (PC), 75 (APC)	40 (PC)	50 (PC), 75 (APC)	TBD	dB	IEC 61300-3-4 method B, λ=1550nm
Polarization extinction ratio, ER	-	-	typ 25, min 21	-	dB	Similar to IEC 61300-3-40, low coherence, λ=1550nm
Polarization angular error, α	-	-	± 2	-	°	
Repeatability of IL	≤ 0.4				dB	IEC 61300-2-2 method B, λ=1550nm
Service life	100 mate/demate cycles				dB	
Operating temperature	-55 to +85				°C	

- NOTES**
- Those values are at BOL, room temperature.
 - For specific fibers and wavelength, please inquire on the optical specification
 - Cable can further limit those values

ENVIRONMENTAL TESTS

	CG	
	LEVEL	METHOD
Thermal cycles	-40°C to +85°C, 20 cycles	IEC 61300-2-22
Humidity	+40°C, 168h	IEC 61300-2-19
Vibration	Sinus, 20g, 15cycles	IEC 61300-2-19
Shock	5 drops, 1.5m	IEC 61300-2-12
Torsion	2N, 25 cycles 180°	IEC 61300-2-5
Static side load	0.2N, 90°, 5min	IEC 61300-2-42
Fiber/cable retention	5N, 1min	IEC 61300-2-4
High temperature storage	+85°C, 168h	IEC 61300-2-18
Mating durability	500	IEC 61300-2-22
Low pressure	-	-
Dust	-	-
Salt mist	-	-
Rapid depressurisation	-	-

	SG and EG	
	LEVEL	METHOD
Thermal cycles	-55°C to +85°C, 100 cycles	IEC 61300-2-22
Humidity	+25°C to +55°C, 6 cycles, 144h	IEC 61300-2-46
Vibration	Random, 35gRMS	IEC 60068-2-64
Shock	500g, 2ms	IEC 60068-2-27
Torsion	2N, 25cycles 180°	IEC 61300-2-5
Static side load	0.2N, 90°, 60min	IEC 61300-2-42
Fiber/cable retention	5N, 2min	IEC 61300-2-4
High temperature storage	+85°C, 1000h	IEC 61300-2-18
Mating durability	100	IEC 61300-2-2
Low pressure	4*10 ⁻⁸ Torr, 8h	IEC 60068-2-13
Dust	30°C to 60°C, 2h	IEC 61300-2-27
Salt mist	+35°C, 85% r.h, 5% salt, 96h	IEC 60068-2-11
Rapid depressurisation	atm to 50mbar in 5s, 5 cycles	MIL-STD.810G

Qualification test reports describe in detail test and results.

TOOLING FOR ASSEMBLING

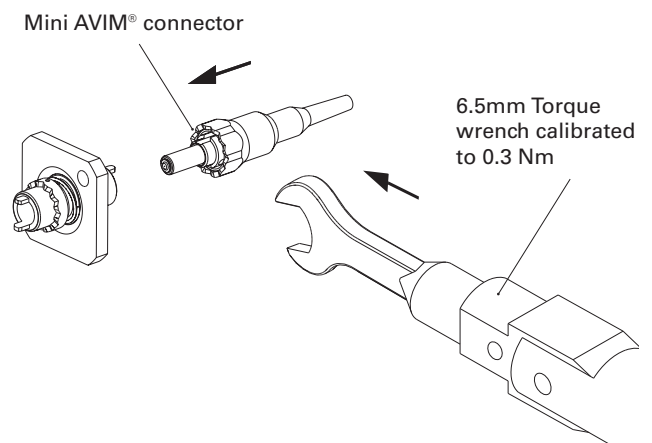
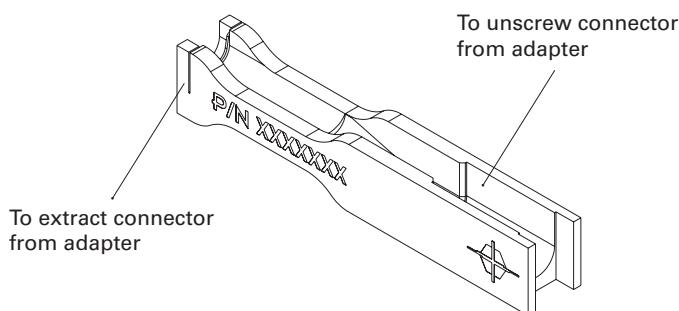

MINI AVIM® ADAPTER AND DIMENSIONS

Available types: Square flange adapter for wall mount

Material: According to part list

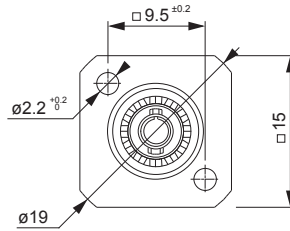
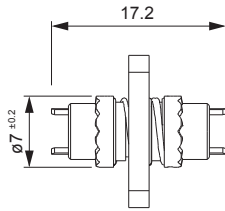
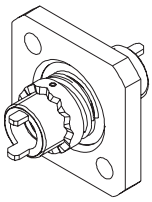

CUTOUT DIMENSIONS

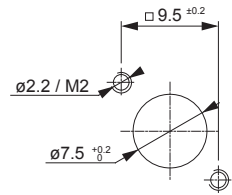

BILL OF MATERIAL - BOM

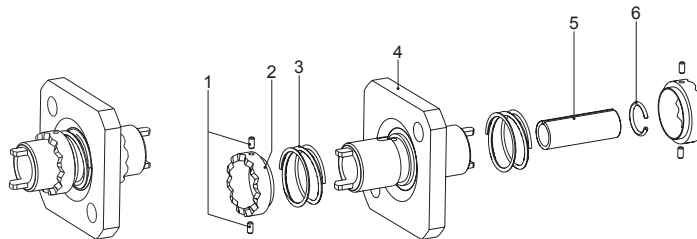

POS.	DESCRIPTION	MATERIAL	WEIGHT (gr.)
1	Pin for Anti-rotation ring (4x)	Ti6AL4V	0.01
2	Anti-rotation ring (2x)	Ti6Al4V	0.20
3	Anti-rotation spring (2x)	AISI 316 or DIN 1.4401	0.14
4	Main body	Ti6Al4V	2.12
5	Split sleeve	ZrO2	0.16
6	Clip for split sleeve	AISI 301 or DIN 1.4310	0.01
Total			2.64

Mini AVIM® CONNECTOR DIMENSIONS

Connectors for 900um buffer coatings (or loose tube) up to 1.2mm cable

Available types: **Mini AVIM® (PC, APC, PM, PS)**

Material: According to part list

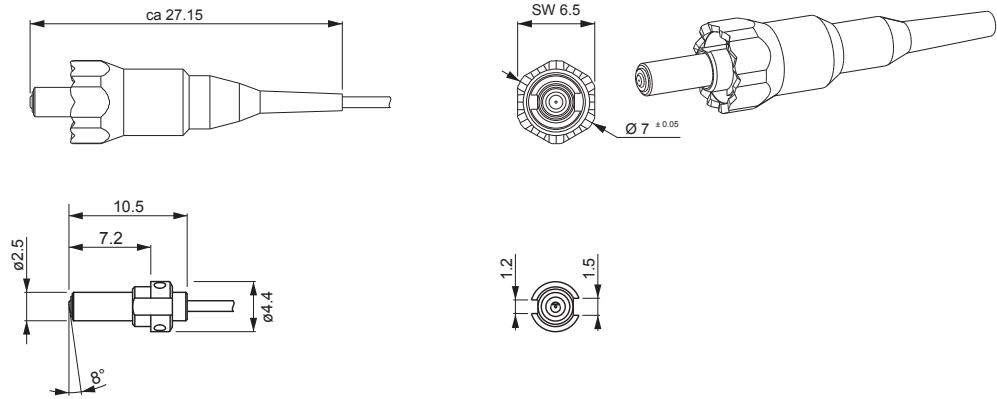

BILL OF MATERIAL - BOM

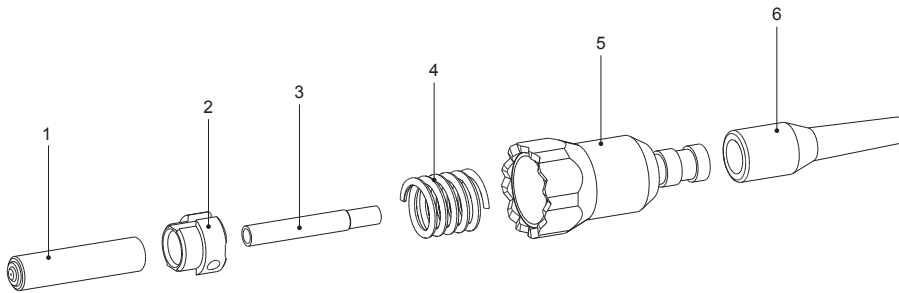

POS.	DESCRIPTION	MATERIAL		UNIT MASS (g)
		NAME	NORMS	
1	Ferrule	Ceramic-Titanium	ZrO ₂ , Ti gr 1	0.21
2	DMI ring	Titanium	Ti6Al4V	0.09
3	Ferrule back tube	Brass	CuZn37	0.03
4	Spring	Stainless steel	1.4310 (AISI 301)	0.11
5	Outside shell	Titanium	Ti6Al4V	0.52
6	Vacuum baked boot	Thermoplastic Elastomer TCP-ET	Hytrel 8068 ¹	0.08
Total				1.06

¹ Vacuum baked, 144h at 110°C to 125°C and 10⁻² Torr

NOTE Diamond's standard **boot** colors are as follows: Black for MM and SM PC, and green for SM APC.

ORDER INFORMATION

Please refer to the part numbers provided in the separate P/N list.

For assemblies or other configurations, please contact your nearest local Diamond representative or fill in the contact form available on the www.diamond-fo.com website.

DIAMOND

Fiber Optic Components

CABLE ASSEMBLIES AND ADAPTERS

In order to ensure the highest technical performance and to provide an optimum solution for high density packaging, DIAMOND has developed the micro AVIM® based on the DMI connectors, but using only titanium components.

The micro AVIM® is identical to the mini AVIM® in terms of termini, but use different locking mechanism borrowed to the DMI.

Micro AVIM® connectors are based on standard $\varnothing 2.5$ mm ferrules and are designed to operate with multimode and single mode fibers, 0° PC as well as 8° APC polished.

Thanks to its minimal space requirement, this system is an ideal solution for Printed Circuit Board (PCB) applications as well as a high quality interface between active and passive components of fiber optic installations.

As such it has been used to replace splices, in some applications, improving the modularity at a low height budget impact.

FEATURES

- ▶ Low IL due to Active Core Alignment (A.C.A.)
- ▶ High return loss due to Diamond ultra-polishing process and A.C.A
- ▶ High vibration/shock resistance due to minimal mass and simple design
- ▶ Very lightweight due to the use of titanium and simplest design
- ▶ ESCC 3420/001 configurable
- ▶ Mating adapter clip simple installation (screw and/or solder)
- ▶ Tooling for installation mandatory

AVAILABLE AS

- ▶ Terminated connectors and assemblies with following optical interface
 - SM, MM, MM large core
 - PM or PZ
 - PS, PM-PS, PSf, PSm
 - Multi-fiber Ferrule
- ▶ Multi-fiber Ferrule
 - Components:
 - Connector Set (require Diamond production line)
 - Mating adapters
 - Custom assemblies
- ▶ Product grades:
 - Commercial Grade, CG
 - Enhanced Grade, EG
 - Space Grade, SG
 - Customized CUST

Micro AVIM®

SINGLE MODE	PC/APC
MULTIMODE	PC
PM	PC/APC
PS, PM-PS, PSF	PC/APC 4°
PSM	PC
HIGH TEMP, HT	PC/APC

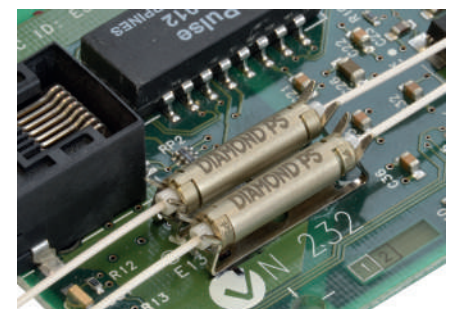

SPECIFICATIONS

The products are available in different grade, changing the operating range and performance. Two tables are provided: Optical performance at room temperature and list of test performed on each product grade.

COMMERCIAL GRADE, CG	SINGLE MODE	MULTIMODE	PM APC 8°	PS APC 4°	UNITS	TEST CONDITIONS
Insertion loss, IL max	typ. 0.2, max 0.4	typ. 0.2, max 0.4	typ. 0.2, max 0.4	typ. 0.2, max 0.4	dB	IEC 61300-3-4 method B, λ=1550nm
Return loss, RL min	50 (PC), 75 (APC)	40 (PC)	50 (PC), 75 (APC)	50 (PC), 75 (APC)	dB	IEC 61300-3-6, λ=1550nm
Polarization extinction ratio, ER min	-	-	typ 27, min 23	-	dB	IEC 61300-3-55 method A
Polarization angular error, α	-	-	± 2	-	°	
Repeatability of IL	≤ 0.5				dB	IEC 61300-2-2 method B, λ=1550nm
Service life	500 mate/demate cycles				dB	
Operating temperature	-40 to +85				°C	

ENHANCED AND SPACE GRADE, EG AND SG	SINGLE MODE	MULTIMODE	PM APC 8°	PS APC 4°	UNITS	TEST CONDITIONS
Insertion loss, IL	typ. 0.25, max 0.5	typ. 0.2, max 0.4	typ. 0.25, max 0.5	TBD	dB	IEC 61300-3-4 method B, λ=1550nm
Return loss, RL	50 (PC), 75 (APC)	40 (PC)	50 (PC), 75 (APC)	TBD	dB	IEC 61300-3-4 method B, λ=1550nm
Polarization extinction ratio, ER	-	-	typ 25, min 21		dB	IEC 61300-3-55 method A
Polarization angular error, α	-	-	± 2		°	
Repeatability of IL	≤ 0.5				dB	IEC 61300-2-2 method B, λ=1550nm
Service life	100 mate/demate cycles				dB	
Operating temperature	-55 to +85				°C	

- NOTES**
- Those values are at BOL, room temperature
 - For specific fibers and wavelength, please inquire on the optical specification
 - Cable can further limit those values

ENVIRONMENTAL TESTS

	CG	
	LEVEL	METHOD
Thermal cycles	-40°C to +85°C, 20 cycles	IEC 61300-2-22
Humidity	+40°C, 168h	IEC 61300-2-19
Vibration	Sinus, 20g, 15cycles	IEC 61300-2-19
Shock	5 drops, 1.5m	IEC 61300-2-12
Torsion	2N, 25 cycles 180°	IEC 61300-2-5
Static side load	0.2N, 90°, 5min	IEC 61300-2-42
Fiber/cable retention	5N, 1min	IEC 61300-2-4
High temperature storage	+85°C, 168h	IEC 61300-2-18
Mating durability	500	IEC 61300-2-22
High power, dry heat	6W, 85°C, 1h	IEC 61300-2-14
Low pressure	-	-
Dust	-	-
Salt mist	-	-
Rapid depressurisation	-	-

TOOLING FOR ASSEMBLING



PN: 1032053
DMI and Micro AVIM®
mounting tool

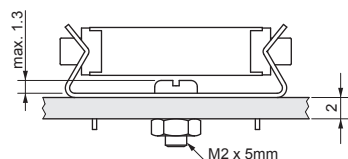

PN: 1009209
DMI and Micro AVIM® Adapter Clip
CuBe Nickel coated (Screw not included)

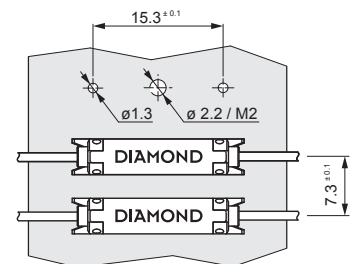

CONNECTOR TYPES AND DIMENSIONS

Micro AVIM® connectors on 900 μm fiber, without boot

Available types: **Micro AVIM® - PC**
Micro AVIM® - APC

Ferrule material: Zirconia/Ti gr 1

External parts: Ti6Al4V

Mass: 0.33 gr

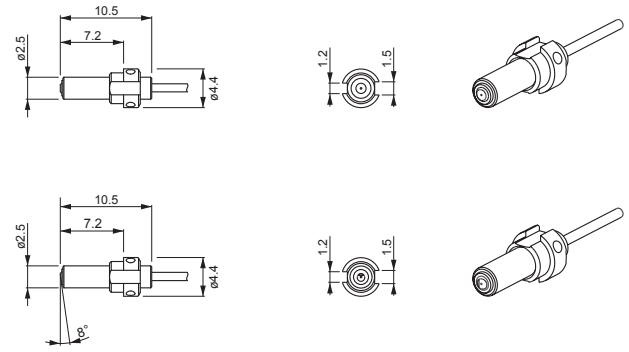

ADAPTER TYPES AND DIMENSIONS

Micro AVIM® mating adapters

External parts: Ti6Al4V

Mating sleeve: Zirconia

Mass: 0.6 gr

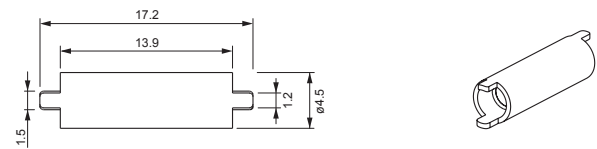

Micro AVIM® mating adapters clip

External parts: Metal (Cu Be2; tinned solderable)

Mass: 0.36 gr

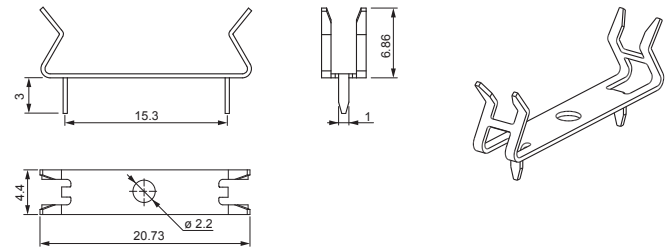

ORDER INFORMATION

Please refer to the part numbers provided in the separate P/N list.

For assemblies or other configurations, please contact your nearest local Diamond representative or fill in the contact form available on the www.diamond-fo.com website.

ACCREDITED LABORATORY

For opto-mechanical product tests, quality control and qualifications Diamond relies since 2002 upon an internal, fully independent, test laboratory qualified by the Swiss Accreditation Service SAS. The laboratory has a STS 0333 accreditation for fiber-optic component testing as well as a SCS 0101 accreditation for the calibration of fiber-optic measurement instruments according to ISO/IEC 17025 :2017.

The laboratory is equipped to perform a wide variety of tests both on the optical or mechanical product performance under different environmental conditions according to IEC, ISO, Telcordia, or MIL standard requirements. Additional characterization procedures that have not yet been standardized are also possible, particularly in relation to the use of high-power lasers.

These testing services are also available to customers.



ISO 6 AND ISO 7 CLEANROOM

For particularly demanding markets such as the medical, the space, life sciences industry sectors, Diamond offers a dedicated controlled environment where to perform part of the product processing. In an ISO 7 cleanroom (class 10'000 according to FED STD 1209E) products can be cleaned, dried, inspected, and packaged before delivery. Specific custom procedures may be implemented upon request.

Cleanroom ISO 7 characteristics:

- ▶ **Class:** ISO 7 (norm DIN EN ISO 14644-1)
- ▶ **Filters:** 3 ULPA U15 filters
- ▶ **ESD-compliant:** yes
- ▶ **Surface:** 40 m²

Cleanroom ISO 6 characteristics:

- ▶ **Class:** IOS 6
- ▶ **Filters:**
- ▶ **ESD-compliant:** yes
- ▶ **Surface:** 180 m²



PRODUCTS PART NUMBER

Mating-Adapters

DESCRIPTION	ORDER NUMBER
Mini AVIM® mating adapter square Flange CG	1058232
AVIM® mating adapter hex flange NS CG	1028003
AVIM® mating adapter square flange NS CG	1073322
Micro AVIM® mating adapter	1023245
Micro AVIM® mating adapter clip	1009209

Hybrid Mating-Adapters

DESCRIPTION	ORDER NUMBER
Mini AVIM® - LSA/AVIM®	1064074
Micro AVIM® - FC NS	1082140
Mini AVIM® - Micro AVIM®/DMI	1065927
LSA/AVIM® - FC wk (key 2.14 mm)	1018449
LSA/AVIM® - FC nk (key 2.00 mm)	1024895
LSA/AVIM® - ST	1018448
LSA/AVIM® - SC SM APC	1018490
LSA/AVIM® - E-2000® SM APC	1018934
LSA/AVIM® - F-3000® (LC) SM APC	1018818

MAS Adapter System

DESCRIPTION	ORDER NUMBER
MAS Mini AVIM® Universal Flange	1059841
MAS adapter E-2000®	1023701
MAS adapter SC	1023681
MAS adapter LSA/AVIM®	1023676
MAS adapter ST™	1018981
MAS adapter F-3000® (LC)	1023682
MAS adapter FC wk (wide key 2.14 mm)	1023677
MAS adapter FC nk (narrow key 2.00 mm)	1023678
MAS FC wk Universal Flange	1022898

IMOD

DESCRIPTION	ORDER NUMBER
IMOD Mini AVIM® PC, stopper on ceramic CG	1080135
IMOD Mini AVIM® APC8, stopper on ceramic CG	1080823

Tools

DESCRIPTION	ORDER NUMBER
AVIM® 6mm torque wrench 0.3Nm for connector	1027834
AVIM® 8mm torque wrench 1.5Nm for mating adapter	1027835
AVIM® 11mm torque wrench 1.0Nm for mating adapter coupling nut	1027836
AVIM® mating adapter holding tool	1030366
Mini AVIM® torque wrench 0.3Nm	1060037
Mini AVIM® un-mounting tool	1060258
Micro AVIM®/DMI mounting tool	1032053
Video Inspection microscope kit	1081582

