

ASSEMBLY INSTRUCTION

**FIBER OPTIC CONNECTORS
MICRO AVIM™**

MINI AVIM™

MIDI AVIM™

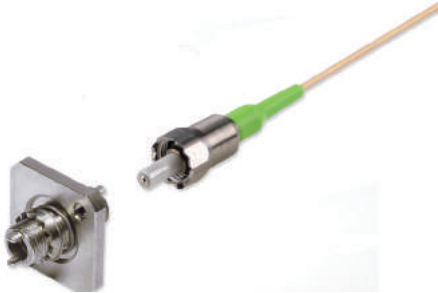

CONTENTS

Page

Updated DS may be download from Diamond SA website

1. ADAPTER AND CONNECTOR MOUNTING USING TORQUE WRENCHES WITH SPECIFIC SETTINGS	
1.1 Mini-Avim mating adapter mounting (square flange)	2
1.2 Mini & Midi-Avim™ connector mounting in the adapter using torque wrench with specific setting	3
1.3 Mounting the Micro-Avim™ connectors into the mating adapter	4
2. DE-MOUNTING CONNECTOR FROM ADAPTER	5
2.1 De-mounting Mini-Avim™ connector from mating adapter	5
2.2 De-mounting Midi-Avim™ connector from mating adapter	5
2.3 Releasing Micro-Avim™ assembling from the clip	5
2.4 Uncoupling the Micro-Avim™ connector from mating adapter	6
3. VISUAL INSPECTION AND CLEANING PROCEDURES	7
3.1 General Information	7
3.2 Fibre optic cleaning and troubleshooting process flow	8
3.3 Complete inspection & Cleaning Kit	9
3.4 Visual inspection of APC/PC unmated connector using the VIAVI microscope	10
3.5 Visual inspection of APC/PC unmated connector (free connector) using the VIAVI “FBP Probe”	11
3.6 Visual inspection of Mini-Avim APC mated connectors (In-adapter inspection)	12
3.7 Visual inspection of Mini-Avim PC mated connectors (In-adapter inspection)	13
4. ACCEPTANCE CRITERIA FOR DIAMOND FERRULES (CU-NI OR TITANIUM)	14
4.1 Visual inspection examples of fibre APC/PC SM 8/125 µm	16
4.2 Visual inspection examples of fibre APC/PC MM 50/62.5/125 µm	16
4.3 Visual inspection examples of APC/PC MM 105/125 µm	17
4.4 Visual inspection examples of PC MM 200/230 µm	18
5. CONNECTOR END FACE CLEANING	19
5.1 Ferrule end face dry cleaning procedure for unmated connectors	19
5.2 Ferrule end face wet cleaning procedure for unmated connectors	19
5.3 Ferrule end face cleaning procedure in bulkhead	20
5.4 Mating adapter screw thread cleaning	21
5.5 Mating adapter sleeve cleaning	21
6. INSPECTION	22
7. INTERCONNECTION MOUNTING TOOLS WITH P.N	24
7.1 Mini-Avim interconnection mounting/DE-Mounting tools	24
8. PART LIST - INSPECTION KITS, ACCESSORIES AND CONSUMABLES & SPECIAL TOOLS	25

1. Adapter and connector mounting using torque wrenches with specific settings

1.1 MINI-AVIM MATING ADAPTER MOUNTING (SQUARE FLANGE)

- A) Without removing the protection caps. Place the mating adapter in the panel with the smaller alignment key positioned at top.

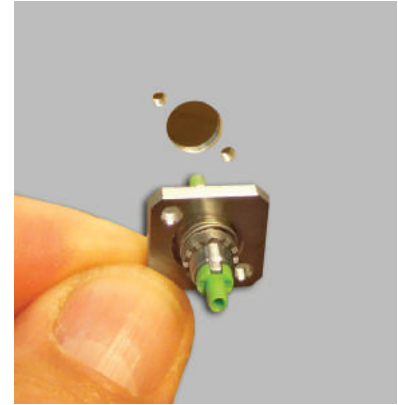

- B) Mount and tighten the two M2 screws. Refer to the screw torque specifications.



1.2 MINI & MIDI- AVIM™ CONNECTOR MOUNTING IN THE ADAPTER USING TORQUE WRENCH WITH SPECIFIC SETTING

- A) Remove the protection cap of the connector and adapter.

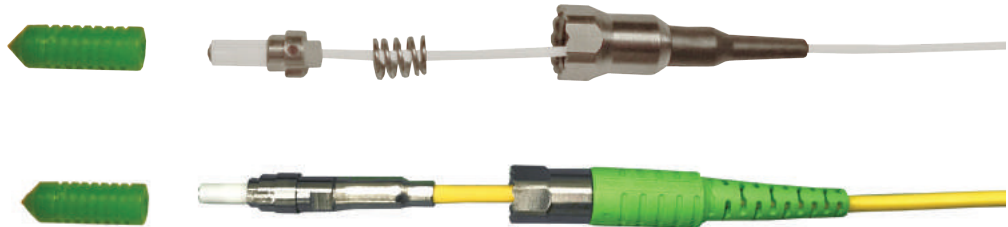

- B) Have the small keyway pointed upwards. By holding the connector at a slight angle gently lean the ferrule on the bottom key.

Straighten the connector with the same axis as the mating adapter and insert the connector until the sleeve has been reached. This avoids damaging/scratching the front surface of the connector.

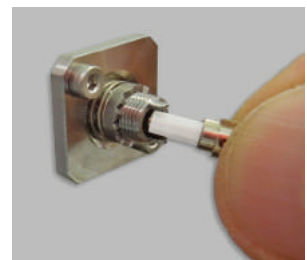

- C) Move the connector slightly clockwise/anti clockwise until the keys fit in the keyways, until the ferrule is completely inserted. Bring the spring and hexagon nut to the adapter. Turn the hexagon nut of the connector clockwise by hand all the way down.

MINI AVIM™



MIDI AVIM™



- D) Final tightening is done using 6.5 mm torque wrench calibrated at 0.3 Nm.



- E) Make sure that the anti-rotation teeth are coupling well. In case turn slightly back the hexagon nut of the connector.



Not OK

OK

1.3 MOUNTING THE MICRO-AVIM™ CONNECTORS INTO THE MATING ADAPTER

- A) Hold the connector at a slight angle and gently lean the ferrule on the bottom key. The connector has a narrow & wide key. Make sure to couple the correct key with the correct keyway. Straighten the connector with the same axis as the mating adapter and insert the connector until the sleeve reaches the shoulder of the mating adapter. This avoids damaging/scratching the front surface of the connector.

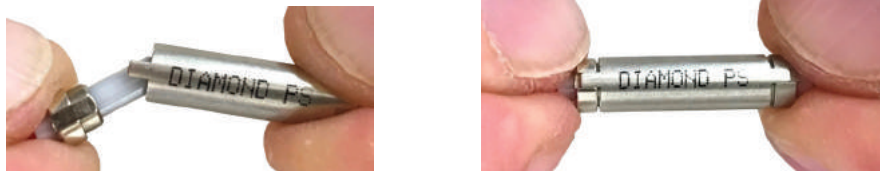

FIXING MICRO-AVIM™ ASSEMBLY ONTO THE CLIP

- B) Position one lateral side of MICRO-AVIM™ assembly into the clip (be sure that the V-Groove of the connector is horizontal (see detail))
 2. Position the other side of assembly and press down on the clip using the special tool.

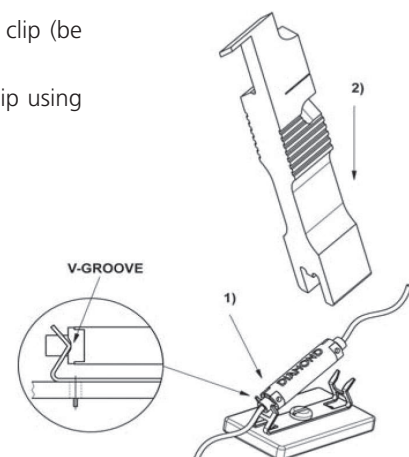

2. DE-MOUNTING CONNECTOR FROM ADAPTER

2.1 DE-MOUNTING MINI-AVIM™ CONNECTOR FROM MATING ADAPTER

- A) Loosen the hexagon nut of the connector. You may use the back part of the extracting tool.

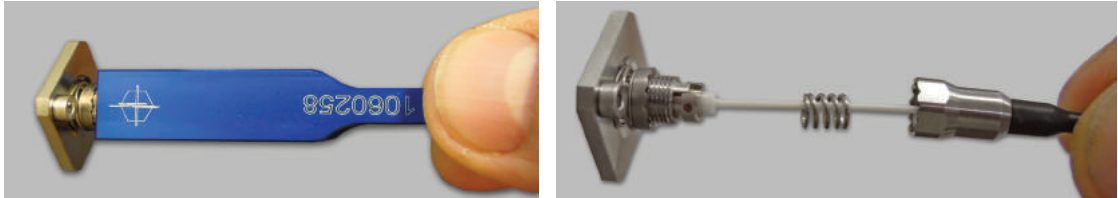

- B) Once the nut is loosened from the thread, Twist the tool around and use the front side of the extract tool to pull the ferrule half way out. Then by hand pull the ferrule straight out gently without any side movement in order to avoid ferrule front surface scratching on the adapter keys.

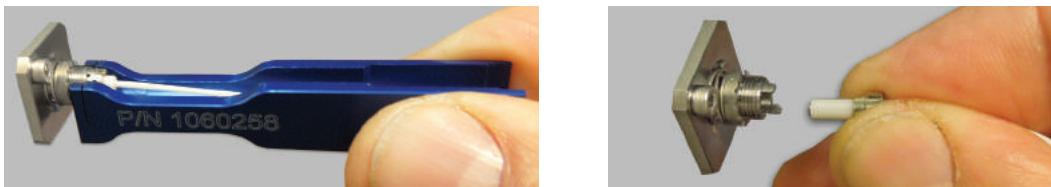

2.2 DE-MOUNTING MIDI-AVIM™ CONNECTOR FROM MATING ADAPTER

Hold the body of the MIDI AVIM™ and gently pull the connector out of the mating adapter.

Having the middle finger out will avoid a return movement towards the adapter keys and hence avoiding damage to the end face of the connector.

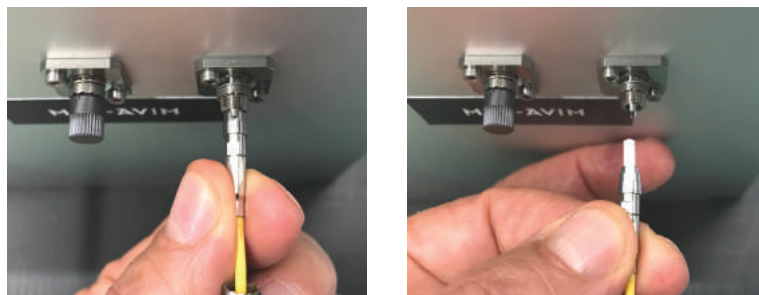

2.3 RELEASING MICRO-AVIM™ ASSEMBLING FROM THE CLIP

1. Position the special tool between MICRO-AVIM™ assembly and clip
2. Push the special tool down to release the MICRO-AVIM™ assembly

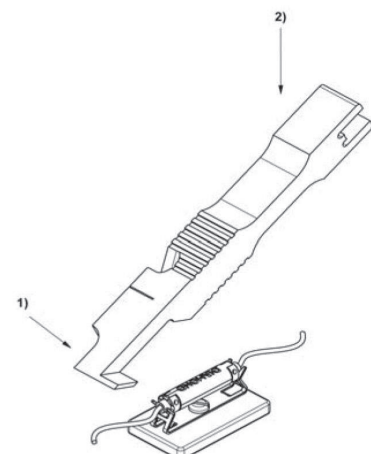

2.4 UNCOUPLING THE MICRO-AVIM™ CONNECTOR FROM MATING ADAPTER

1. Position the assembly on the special tool.
(Be sure that the blade of the tool is positioned between connector and adapter)
2. Pull the assembly to uncouple connector from adapter

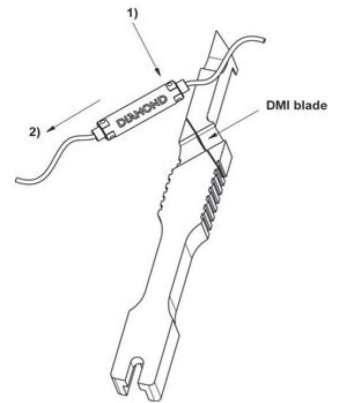

3. VISUAL INSPECTION AND CLEANING PROCEDURES

3.1 GENERAL INFORMATION



Warning: Invisible laser radiation might be emitted from disconnected fibres or connectors. Do not stare into beams or view directly with optical instruments. Make sure that the lasers are turned off before you begin the inspection. It is important that every fibre connector is inspected and cleaned prior to mating. This chapter describes inspection techniques and cleaning procedures for fibre optic connections.

Any microscopic dust particles can cause a variety of problems for optical connections. Dust particles trapped between two fibre faces can scratch the glass surfaces. Even if a particle is only situated on the cladding or the edge of the end face, it can cause an air gap or misalignment between the fibre cores which significantly degrades the optical signal. The tolerance to dirt is near zero so always have the protection caps on adapter/connector if not in use/connected in order to avoid dust getting on the surface.

DIAMOND offers a wide range of products in order to allow a safe connector inspection and cleaning.

3.2 FIBRE OPTIC CLEANING AND TROUBLESHOOTING PROCESS FLOW

Fibre Optic Cleaning and Troubleshooting

Process Flow

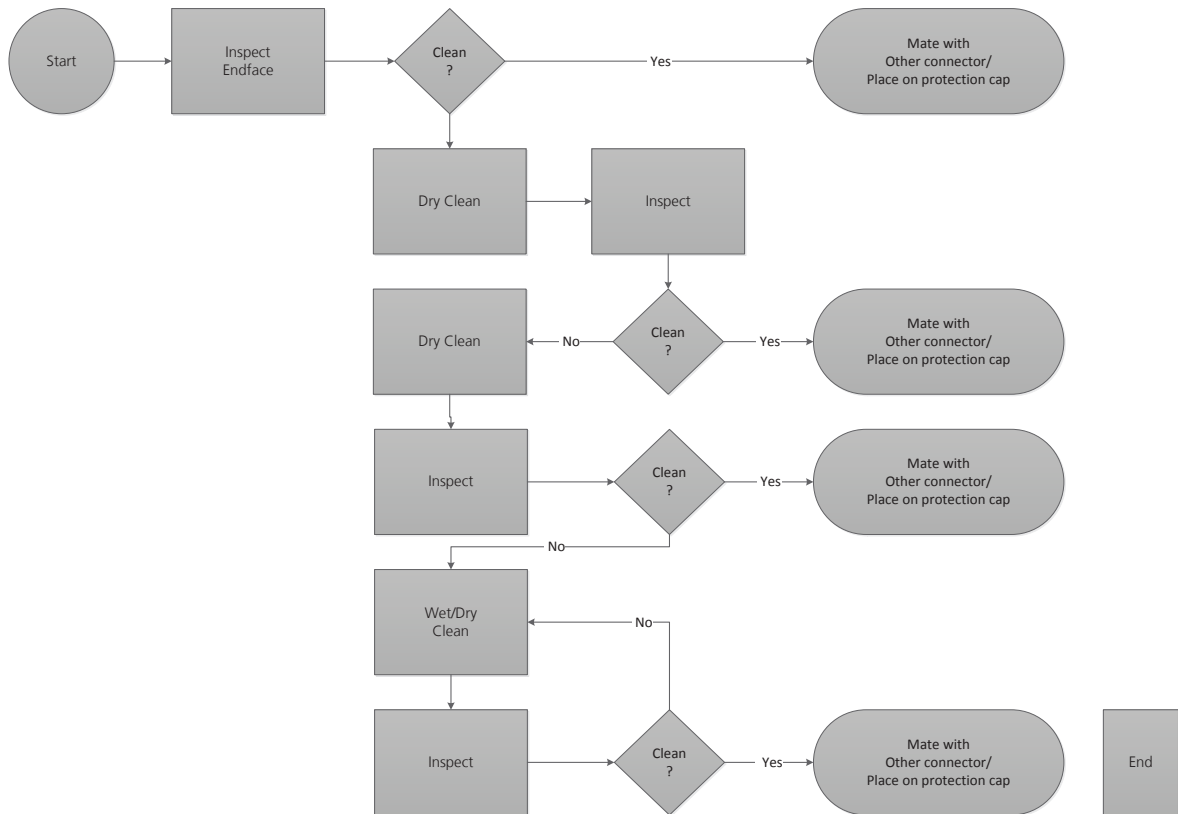

If after repeated cleaning the connector still does not meet the acceptance criteria, the connector must be replaced or re-polishing.

Re-polishing should only be performed by trained personnel using Diamond polishing machines and should only be performed on-site when absolutely necessary. Always keep the protective cap on the connector when not in use.

3.3 COMPLETE INSPECTION & CLEANING KIT



INSPECTION PROBE CONNECTED TO PC/LAPTOP





VIDEO INSPECTION MICROSCOPE

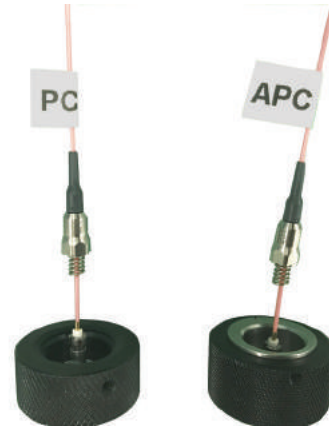

There is no danger of eye injury due that the monitor is optically separated from the connector.

3.4 VISUAL INSPECTION OF APC/PC UNMATED CONNECTOR USING THE VAVI MICROSCOPE

Ø2.5mm adapter PC for unmated simplex connectors	1070134	
Ø2.5mm adapter APC for inspecting unmated simplex connectors	1083929	

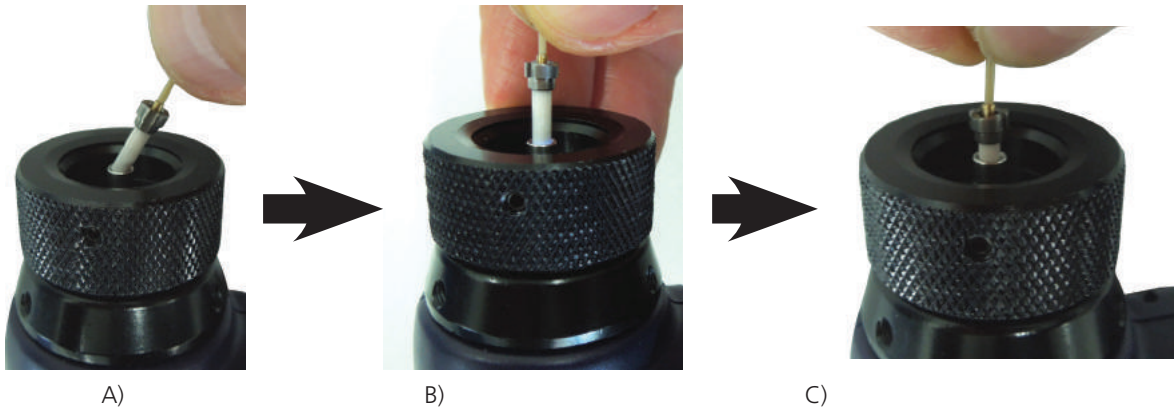

- A) By holding the connector at a slight angle gently lean it in the adapter $\varnothing 2.5\text{mm}$ hole. This avoids damaging/scratching of the connector front surface.
- B) Straighten the connector with the same axis as the adapter.
- C) Insert the ferrule as far as it will go and inspect.
- D) For APC version rotate the ferrule until you have a clear image.

3.5 VISUAL INSPECTION OF APC/PC UNMATED CONNECTOR (FREE CONNECTOR) USING THE VAVI "FBP PROBE"



The probe may either be connected to the microscope or to a laptop.

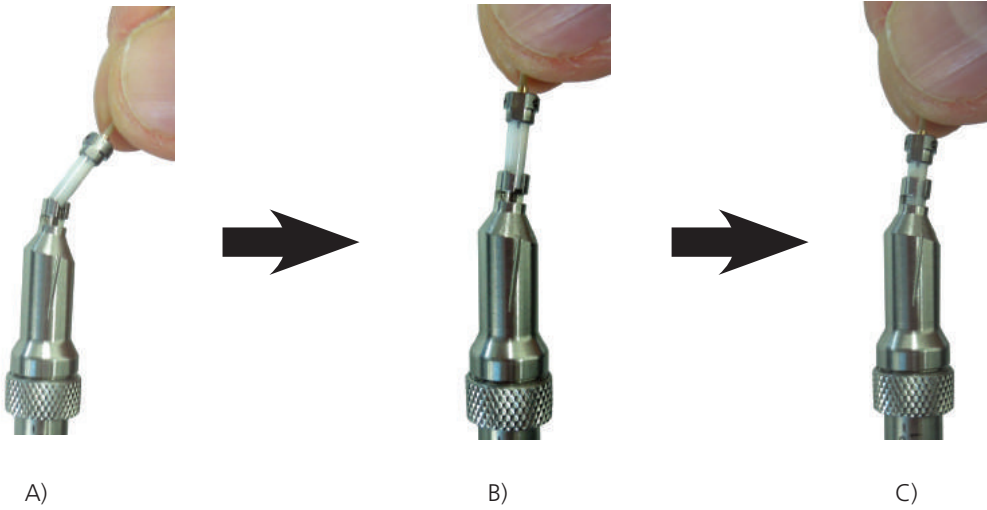

- A) By holding the connector at a slight angle gently lean it in the adapter tip $\varnothing 2.5\text{mm}$ hole. This avoids damaging/scratching of the connector front surface.
- B) Straighten the connector with the same axis as the adapter.
- C) Insert the ferrule as far as it will go and inspect.

To capture the image quicker, align the wide Key with the mark on the adapter tip.

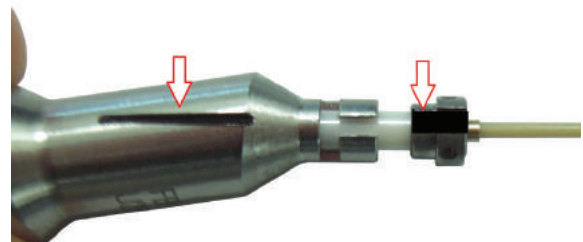

Adapter FBPT U25M for PC 2.5mm free connector inspection

PN: 1074969

Adapter FBPT U25MA for APC free connector inspection

PN: 1074971



3.6 VISUAL INSPECTION OF MINI-AVIM APC MATED CONNECTORS (IN-ADAPTER INSPECTION)



The probe may either be connected to the microscope or to a laptop.



APC in-adapter inspection.

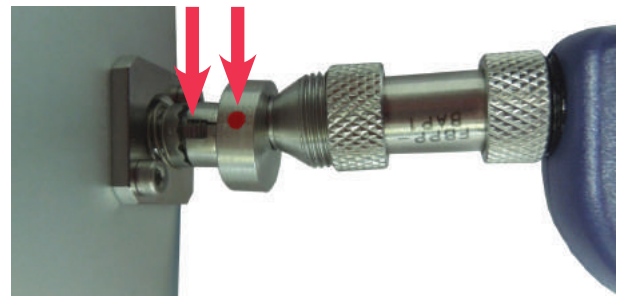

Make sure that the dot of the APC adapter tip is aligned with the wide key.

Mini-Avim adapter for APC in-adapter inspection (bulkhead)

PN: 1079317



3.7 VISUAL INSPECTION OF MINI-AVIM PC MATED CONNECTORS (IN-ADAPTER INSPECTION)



The probe may either be connected to the microscope or to a laptop.

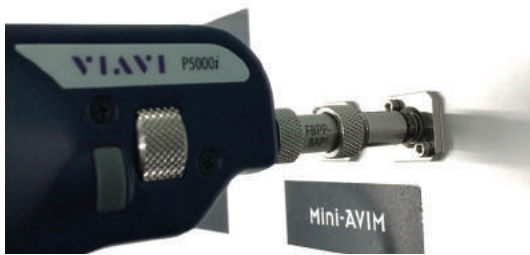

APC in-adapter inspection.

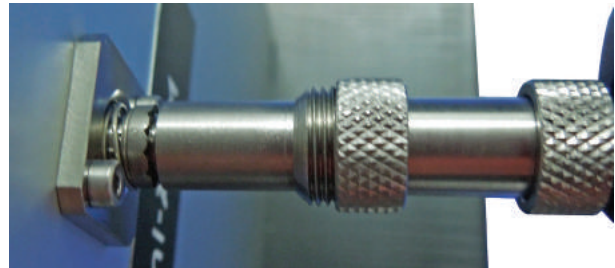

Mini-Avim adapter for PC in-adapter inspection (bulkhead)

PN: 1079313



4 ACCEPTANCE CRITERIA FOR DIAMOND FERRULES (CU-NI OR TITANIUM).

Do refer to the official document "Acceptance Criteria for Installed Connectors". The document refers to the surface control and acceptance criteria of ferrule end face quality for DIAMOND standard ferrules installed in the field. (Pay attention: This document is not for nonstandard ferrules.)

Document No. 1950852

Extranet: No. 720

DISCLAIMER

Diamond provides connectors respecting the criteria below, but with mating and de-mating the optical surface will degrade visually while the optical performance (IL, RL) remain normally intact. Visual Inspection is NOT a valid return criteria.

The reliable assessment of the power transmission and/or the reflection performances in an optical link between two fibers should be performed through direct measurements of IL and RL since those are the values that the end user will actually observe once the system is deployed.

Visual inspection for surface imperfections is an acceptable back-up solution in case direct measurements cannot be performed. However, it can only indicate the suitability of a connection for use but cannot guarantee that IL and RL specifications are going to be met. In this context, visual inspection should be considered only as a qualitative assessment of the connector's performance.



VISUAL INSPECTION EXAMPLES OF DIFFERENT FIBRE DIAMETERS

4.1 VISUAL INSPECTION EXAMPLES OF FIBRE APC/PC SM 8/125 μm

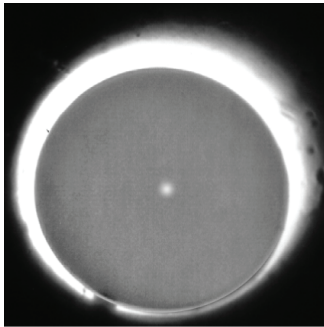

Accepted

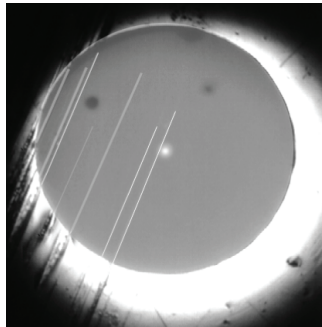

Rejected
Scratches on the fibre

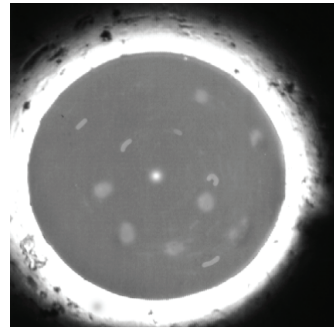

Rejected
Dirt on the fibre

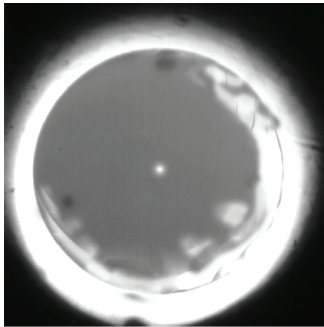

Rejected
Damaged fibre

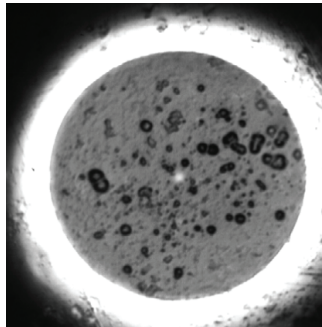

Rejected
Dirt on the fibre

4.2 VISUAL INSPECTION EXAMPLES OF FIBRE APC/PC MM 50/62.5/125 μm

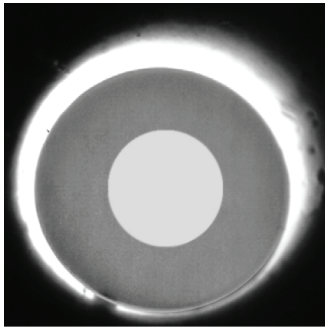

Accepted

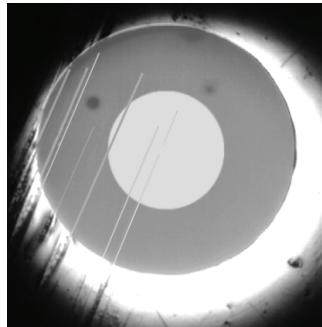

Rejected
Scratches on the fibre

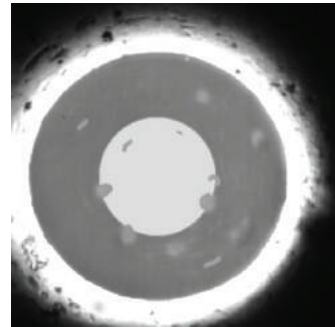

Rejected
Dirt on the fibre

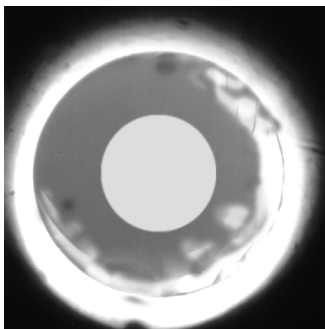

Rejected
Damaged fibre

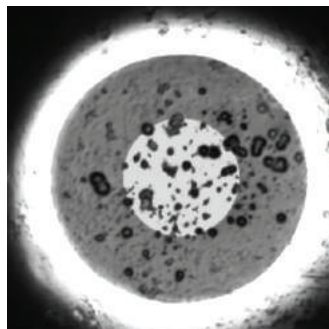

Rejected
Dirt on the fibre

4.3 VISUAL INSPECTION EXAMPLES OF APC/PC MM 105/125 μm

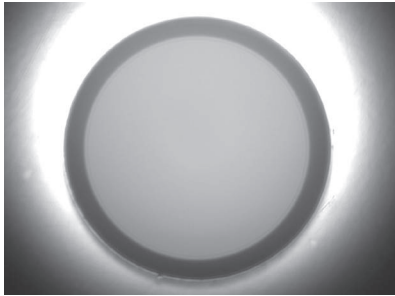

Accepted

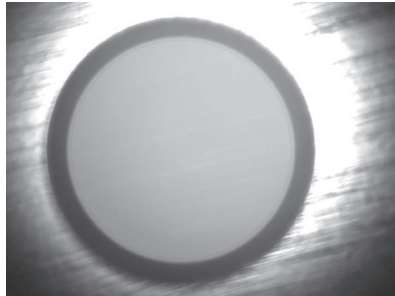

Rejected
Scratches on the fibre

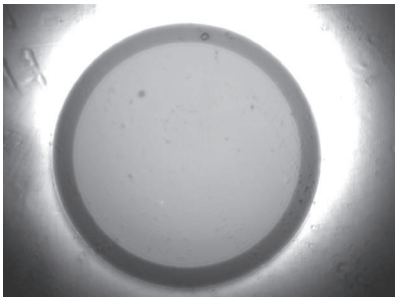

Rejected
Dirt on the fibre

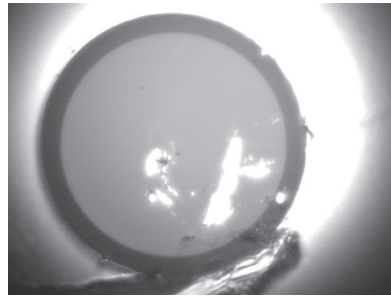

Rejected
Damaged fibre

4.4 VISUAL INSPECTION EXAMPLES OF PC MM 200/230 μm

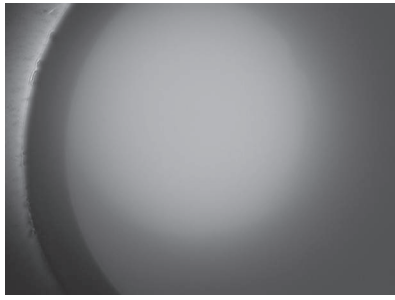

Accepted

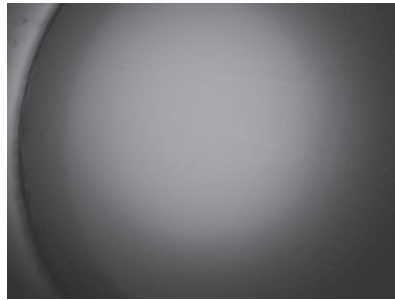

Rejected
Scratches on the fibre

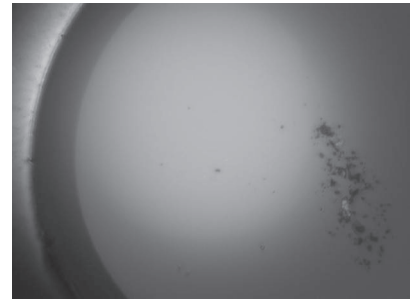

Rejected
Dirt on the front face

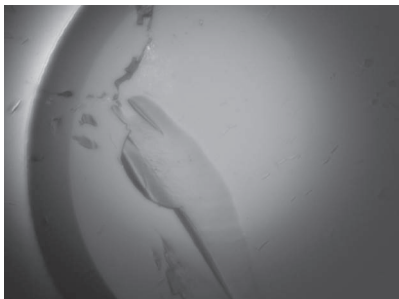

Rejected
Damaged fibre

5 CONNECTOR END FACE CLEANING

5.1 FERRULE END FACE DRY CLEANING PROCEDURE FOR UNMATED CONNECTORS



- A) When the lever is pushed down, the metal protection cover automatically slides back and a new section of tape appears, ready for use.
- B) Keep the lever down, hold the ferrule front face onto the tape and slide along the entire tape in the indicated direction .
- C) Attention: the same part of the tape may be used only once.
- D) Close the metal protection cover by releasing the lever.
- E) Inspect the connector referring to the “Acceptance Criteria” document. If the connector face is not clean repeat the procedure.
- F) If the result is not positive even after repeated cleaning, try with the wet procedure.

5.2 FERRULE END FACE WET CLEANING PROCEDURE FOR UNMATED CONNECTORS

- A) Fold a new a lint-free, disposable wipe three times to obtain a cleaning surface cushioned with more layers of folded material.
- B) Moisten a small area of the cleaning surface with some 99% isopropyl alcohol, ensuring that a small area of the surface remains dry.
- C) Moisten the connector with the tissue and leave it to act briefly. Rotate the ferrule on the moistened tissue with an axial movement several times applying a slight pressure.



5.3 FERRULE END FACE CLEANING PROCEDURE IN BULKHEAD



End face of the ferrule may be cleaned by using the "Ferrule Mate Cleaner", 2,5mm (Seikoh Giken)

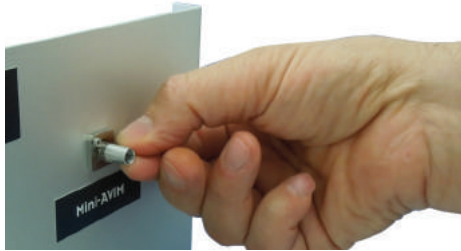

Place the appropriate guide on the adapter



Insert the ferrule mate in the guide all the way down



Press the rectangular button 2-3 times.

Be careful not to slant the panel cleaner while inserting it into the adapter. With the panel cleaners 90% of cases is carried out without problems, there is a 20% of cases where cleaning won't meet the criteria. If so try to pull out the connector from the mating adapter and clean it with isopropyl alcohol as described previously. Sometimes it might be better to leave an optical port alone unless signal effecting contamination is observed blocking the core. Contaminants can be pushed onto the end face during cleaning.

Seikoh Giken Ferrule cleaner "Ferrule Mate", 2,5mm

PN: 1030609



Ferrule Mate guide for in-adapter cleaning (bulkhead)

PN: 1079315



IBC-M250 for in adapter cleaning. This cleaner does **not** reach the ferrule end face.

PN: 1070125



- E) Rotate the ferrule on dry zone of the tissue with an axial movement several times applying a very slight pressure.
- F) Inspect the connector referring to the according "Acceptance Criteria" document. If the connector face is not clean repeat the procedure.
- G) If the result is not positive even after repeated cleaning, we recommend re-polishing or replacing the connector.
- H) Re-polishing may be carried out only by specially trained staff and with the appropriate tools and devices.

5.4 MATING ADAPTER SCREW THREAD CLEANING

- A) Use a nylon brush to brush away any visible dirt from the threads. Follow the thread all the way round.



- B) With clean air blow away any remaining dirt.



- C) Clean the internal sleeve, see below.

5.5 MATING ADAPTER SLEEVE CLEANING

- A) The mating adapter sleeve can only be cleaned if no connector is inserted.
- B) Clean the mating sleeve with a new cleaning stick by pushing it in and out and simultaneously rotating it. Never reuse a cleaning stick.



- C) If the mating adapter is not going to be used immediately, protect it with the appropriate protection caps.
- D) Very dirty or damaged mating adapters must be replaced.

6. INSPECTION

The ML3S Visual Fault Locator is a hand-held, lightweight, visible laser light source used to identify tight bends or crimps, damaged components, bad splices fiber breaks and also to isolate high losses and faults in fibers cables. By emitting a bright beam of red light into a fiber, breaks can be seen as a glowing red light. The ML3S can be used with either singlemode or multimode cable sections. Model ML3S is recommended for applications in cable length up to 6-8 km.



Characteristics:

- ▶ For Singlemode and Multi-Mode Fiber
- ▶ Small and easily manageable, robust
- ▶ Universal style optical port connector 2,5 mm.
- ▶ Universal 1.25mm Adapter as option
- ▶ Operating Distance: approximately 8 km

Technical Characteristics:

- ▶ Output power: 3 mW; -9 dBm in the SM 9/125 μ Fiber
- ▶ Emittertype Laser: (FDA and IEC Class III)
- ▶ Wavelength: 650 nm (visible)
- ▶ Port connector: 2,5 mm Universal fix or 1,25mm Adapter optional
- ▶ Modulation: 2 Hz or continuous
- ▶ Weight: 60 g without batteries
- ▶ Dimension: 170x15 mm
- ▶ Electric power supply: 2 AA Battery for approx. 5 hours operating
- ▶ Operating temperature: -10° to +50° C
- ▶ Storage Temperature: -20° to +80°C
- ▶ Humidity: 0 to 95% (non-condensing)

Use the following procedure for fault locate detection:

1. Remove the dust cap covering the unit's OPTICAL PORT.
2. Connect a cable to the OPTICAL PORT connector.
3. Push the switch to the to the desired function:
 - Turns the LASER off.
 - Turns the LASER on with a continuous laser output. The red Laser Active LED remains on.
 - Turns the LASER on with a pulsing laser output. (The red Laser Active LED pulses at a 2 Hz rate).
4. Visually examine the fiber components, locating the faults by a red glow (see Figure 1).
5. Turn unit off.
6. Remove cable from port and replace cap.

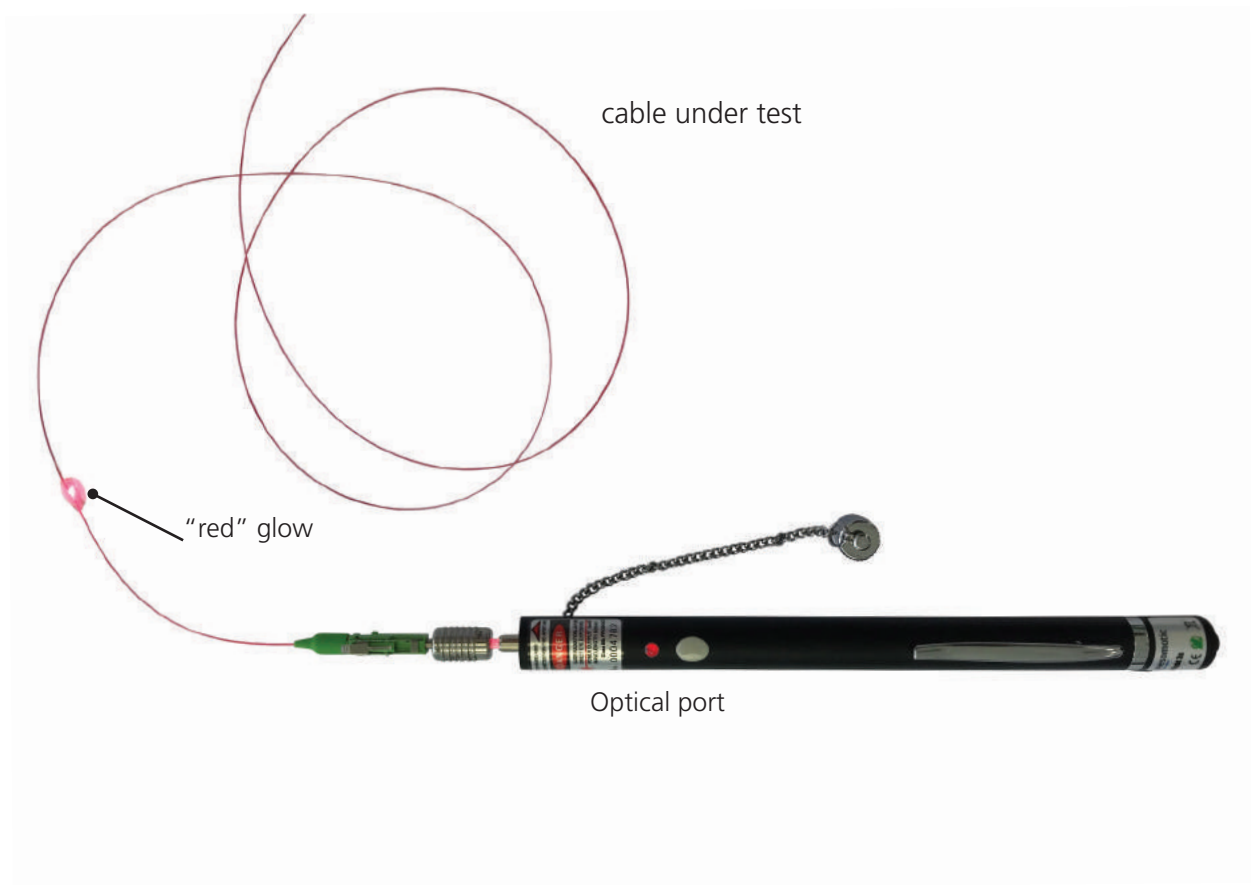





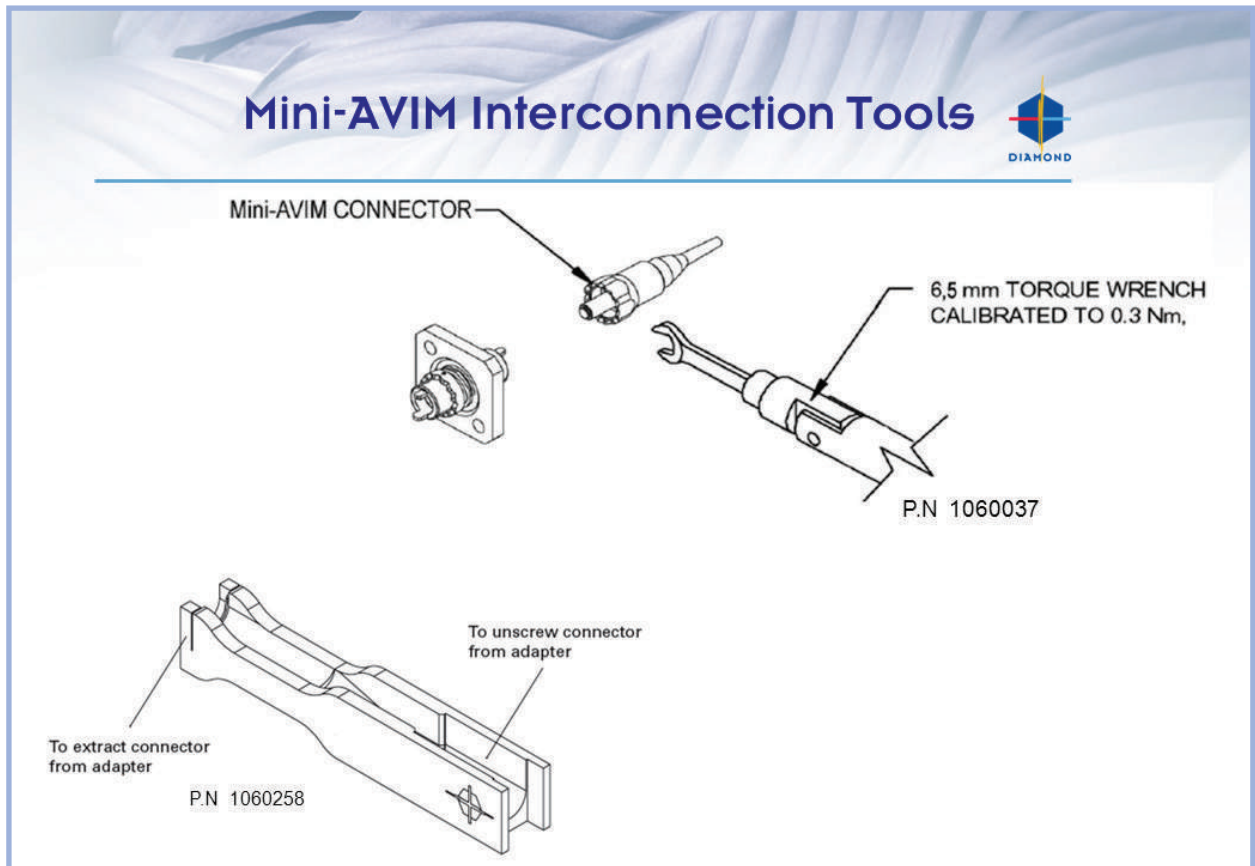









7 INTERCONNECTION MOUNTING TOOLS WITH P.N

7.1 MINI-AVIM INTERCONNECTION MOUNTING/DE-MOUNTING TOOLS

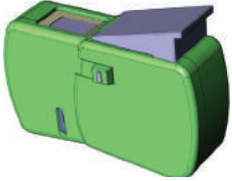

8 PART LIST – INSPECTION KITS, ACCESSORIES, CONSUMABLES & SPECIAL TOOLS

DESCRIPTION	PN	PHOTO
Digital video inspection microscope kit	1081582	
P5000i Digital inspection probe, including universal 2.5mm (PC) tip for free connector inspection. Further tips maybe ordered. Laptop is excluded	1074601	
Mini-Avim adapter for PC in-adapter inspection (bulkhead)	1079313	
Mini-Avim adapter for APC in-adapter inspection (bulkhead)	1079317	
Adapter FBPT U25M for PC 2.5mm free connector inspection	1074969	
Adapter FBPT U25MA for APC 2.5mm free connector inspection	1074971	
Adapter Ø2.5mm for inspection microscope FMD-200	1070134	
Ferrule Mate guide for in-adapter cleaning (bulkhead)	1079315	

DESCRIPTION	PN	PHOTO
Seikoh Giken Ferrule cleaner "Ferrule Mate", 2,5 mm (Seikoh Giken)	1030609	
CleTOP cleaning sticks L=150mm ø2.5 5pz	1065369	
Doser alcohol 150ml (without alcohol)	1070135	
Spender box with fibre optic lint-free wipes 10x10 cm 100Stk.	1070137	
Fibre optic lint-free wipes to refill spender box 100pcs.	1070130	
CleTOP Cassette Cleaner Type B	1038981	
Replacement reel for CleTOP Cassette Cleaner Type B	1038970	

DESCRIPTION	PN	PHOTO
Sticklers™ cleaner. The product fulfills flight regulations (non-flammable).	1073654	
30ml sealed alcohol. (can be transported by plane)	1074474	
Visual fault locator ML3.	1071628	
Nylon brush	1020702	
Magnifying eye lens	1020640	
Torque Wrench calibrated to 0.3Nm S = 6.5mm Used for fastening the Mini-AVIM™ connector	1060037	
Mini-AVIM™ de-mounting/extractor tool	1060258	
Micro-AVIM™ de-mounting/extractor tool	1032053	